



**Gianni
Ferrari**

Turboloader

M220

M280

M360



**CATALOGO PARTI DI RICAMBIO
CATALOGUE PIECES DETACHEES
ERSATZTEILKATALOG
PARTS MANUAL**

01.02.2012

**INDICE****PART LIST**

RUOTE	TAV-01	WHEELS
TELAIO	TAV-02	FRAME
SERBATOIO OLIO - RADIATORE	TAV-03	OIL TANK - RADIATOR
BATTERIA - FILTRO ARIA	TAV-04	BATTERY - AIR FILTER
SERBATOIO CARBURANTE	TAV-05/05A	FUEL TANK
BRACCIO SOLLEVAMENTO	TAV-06/06A	LIFTING ARM
BRACCIO SFILO	TAV-07/07A/07B	TELESCOPIC ARM
PIASTRA AGGANCIAMENTO ATTREZZI	TAV-08/08A	FITTING PLATE
CILINDRI SFILO	TAV-09	CYLINDERS FOR TELESCOPIC
CILINDRI SOLLEVAMENTO	TAV-10	LIFTING CYLINDERS
SNODO CENTRALE	TAV-11	CENTRAL ARTICULATION
SISTEMA ANTIRIBALTAMENTO	TAV-12	ANTI-OUVERTURNING DEVICE
POMPA - MARMITTA - MOTORE	TAV-13	PUMP - MUFFLER - ENGINE
COMANDI IDRAULICI	TAV-14	HYDRAULIC CONTROLS
PRESE AUSILIARIE	TAV-15	SWIFT CONNECTIONS
DEVIATORE COMANDI	TAV-16	CONTROLS SWITCH
VALVOLE DOPPIO PEDALE	TAV-17	DOUBLE PEDAL VALVES
POMPA IDRAULICA	TAV-18	HYDRAULIC PUMP
MOTORI IDRAULICI	TAV-19	HYDRAULIC MOTORS
JOYSTICK	TAV-20	JOYSTICK
DISTRIBUTORE	TAV-21	DISTRIBUTOR
SEDILE - COMANDI	TAV-22	SEAT - CONTROLS
ABITACOLO	TAV-23	PASSENGER COMPARTMENT
CARENATURE POSTERIORI	TAV-24	REAR COVER
CARENATURE ANTERIORI	TAV-25	FRONT COVER
ROPS ABBATTIBILE	TAV-26	FOLDABLE ROPS
ROPS - FANALI	TAV-27	ROPS - LIGHTS
CABINA - RISCALDAMENTO	TAV-28	CAB - HEATING SYSTEM
CABINA - VETRI		CAB - WINDOWS & GLASS

**TABLES DES MATIERES****STÜCK LISTE**

ROUES
CHASSIS
RESERVOIR HUILE - RADIATEUR
BATTERIE - FILTRE A AIR
RESERVOIR CARBURANT
BRAS DE RELEVAGE
BRAS TELESCOPIQUE
PLAQUE OUTILS
CYLINDRES BRAS TELESCOPIQUE
CYLINDRES DE RELEVAGE
ROTULE CENTRAL
DISPOSITIF ANTI-RENVERSEMENT
POMPE - POT - MOTEUR
COMMANDES HYDRAULIQUES
PRISES AUXILIAIRES
COMMUTATEUR COMMANDES
VANNE DOUBLE PEDALE
POMPE HYDRAULIQUE
MOTEURS HYDRAULIQUES
JOYSTICK
DISTRIBUTEUR
SIEGE - COMMANDES
HABITACLE
CARENAGES POSTERIEURES
CARENAGES ANTERIEURES
ROPS PLIABLE
ROPS-FEUX
CABINE - CHAUFFAGE
CABINE - GLACES

TAV-01
TAV-02
TAV-03
TAV-04
TAV-05/05A
TAV-06/06A
TAV-07/07A/07B
TAV-08/08A
TAV-09
TAV-10
TAV-11
TAV-12
TAV-13
TAV-14
TAV-15
TAV-16
TAV-17
TAV-18
TAV-19
TAV-20
TAV-21
TAV-22
TAV-23
TAV-24
TAV-25
TAV-26
TAV-27
TAV-28

RÄDER
RAHMEN
ÖLTANK - KÜHLER
BATTERIE - LUFTFILTER
KRAFTSTOFFBEHÄLTER
HUBARM
TELESKOPARM
BLECH FÜR DIE ZUBEHÖRE
ZYLINDERS FÜR TELESKOPARM
HUBZYLINDERS
ZENTRALKNICKGELENK
SCHUTZVORRICHTUNG GEGEN KIPPEN
PUMPE - SCHALLDÄMPFER - MOTOR
HYDRAULISCHE ANTRIEBS
HILFSKUPPLUNGEN
ANTRIEBSWECHSELSCHALTER
DOPPELPEDALVENTIL
HYDRAULIKPUMPE
HYDRAULIKMOTOREN
JOYSTICK
VERTEILER
SITZ - ANTRIEBS
FAHRGASTRAUM
HINTERE VERKLEIDUNGEN
VORDERE VERKLEIDUNGEN
ABKLAPPBARER ROPS
ROPS-LICHTE
KABINE - HEIZUNG
KABINE - SCHEIBEN

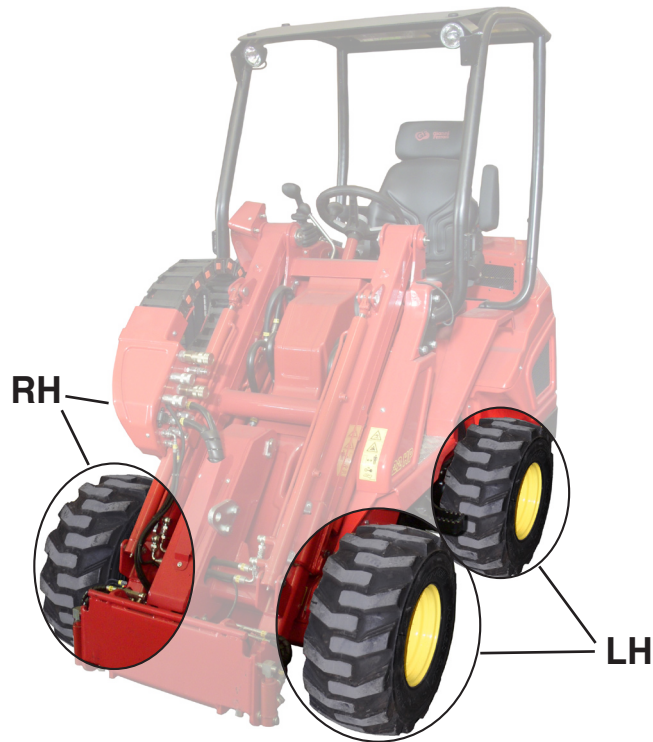
23"

Ref.	Code	Q.ty	Leg.	"	Tread
1	00.72.20.0015	2	RH	23"	H.D.
1	00.72.20.0016	2	LH	23"	H.D.
1	00.72.20.0020	4		23"	GARDEN
1	00.72.20.0030	2	RH	23"	TRACTOR
1	00.72.20.0031	2	LH	23"	TRACTOR
2	00.59.00.1060	4		23"	H.D.
2	00.59.00.0042	4		23"	GARDEN
2	00.59.00.0083	4		23"	TRACTOR
3	00.16.20.0040	4		23"	
4	00.68.08.0510	4			
5	00.18.04.0065	4			
6	00.68.05.0020	20			
7	00.92.08.3061	20			

26"

Ref.	Code	Q.ty	Leg.	"	Tread
1	00.72.20.0011	2	RH	26"	H.D.
1	00.72.20.0018	2	LH	26"	H.D.
1	00.72.20.0013	4		26"	GARDEN
1	00.72.20.0035	2	RH	26"	TRACTOR
1	00.72.20.0036	2	LH	26"	TRACTOR
2	00.59.00.1090	4		26"	H.D.
2	00.59.00.1080	4		26"	GARDEN
2	00.59.00.1100	4		26"	TRACTOR
3	00.16.20.0020	4		26"	

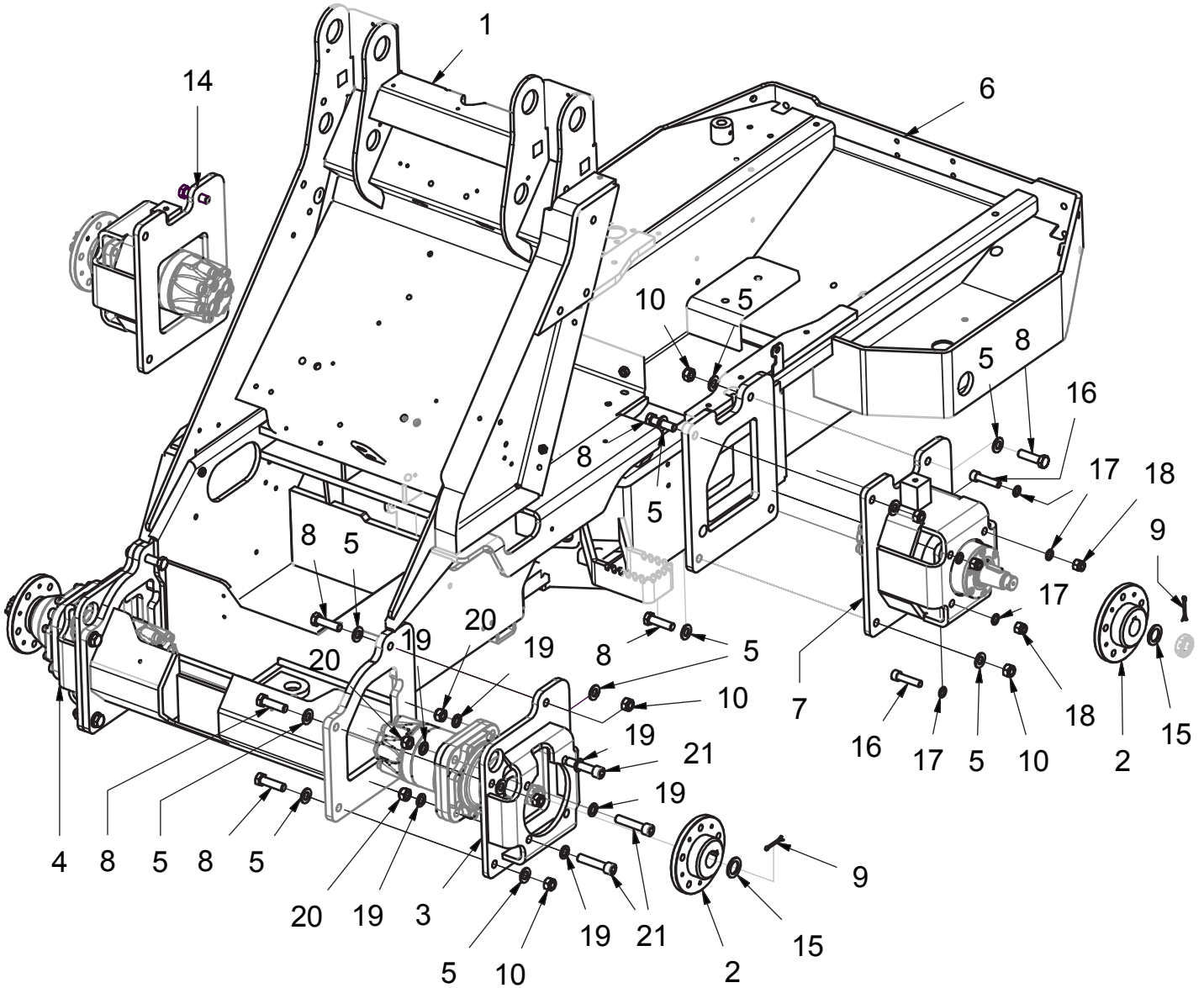

Ref.	Leg.	Code	Q.ty	Ref.	Leg.	Code	Q.ty
1		01.50.20.0040	1	11		00.92.08.1100	12
2		01.40.20.0010	4	12		00.68.01.0030	10
3		01.50.20.0143	1	13		01.50.20.0059	1
4		01.50.20.0150	1	14		01.50.20.0080	1
5		00.68.01.0060	32	15		00.68.08.0510	4
6		01.50.20.0050	1	16		00.90.08.0150	8
7		01.50.20.0070	1	17		00.68.01.0050	16
8		00.92.08.1100	16	18		00.26.04.0090	8
9		00.18.04.0065	4	19		00.68.01.0060	16
10		00.68.01.0050	16	20		00.26.04.0091	8
				21		00.90.09.0173	8

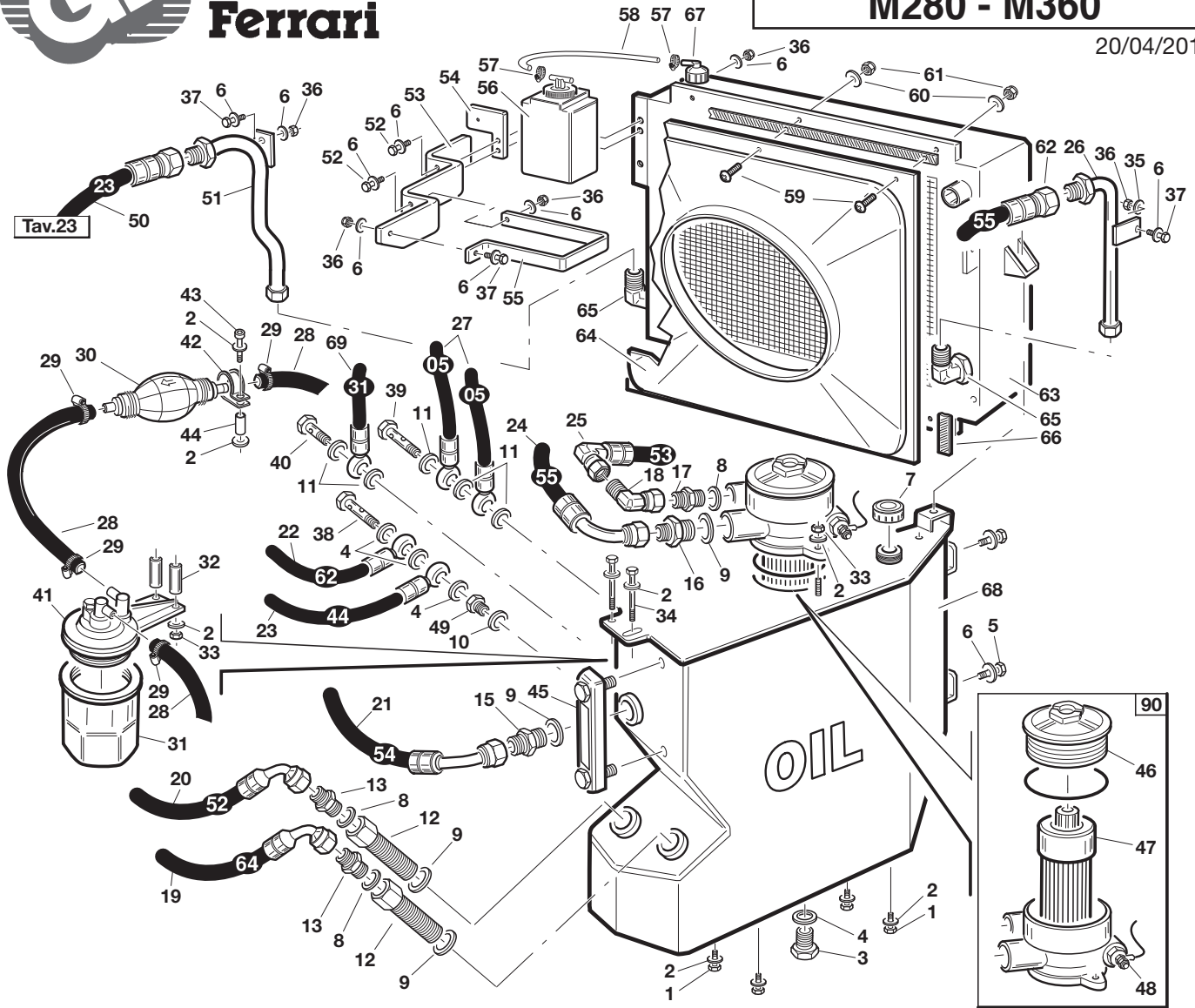

Ref.	Leg.	Code	Q.ty	Ref.	Leg.	Code	Q.ty	Ref.	Leg.	Code	Q.ty
1		00.92.05.1070	4	26		00.41.20.0084	1	48		00.32.20.0013	1
2		00.68.01.0030	12	27		00.41.20.0014	2	49		00.41.00.0914	1
3		00.85.02.0003	1	28		00.89.02.0000	mm800	50		00.41.20.0140	1
4		00.41.00.0070	4	28		00.89.02.0000	mm470	51		00.41.20.0083	1
5		00.92.03.1040	2	28		00.89.02.0000	mm320	52		00.92.03.1090	2
6		00.68.01.0020	10	29		00.29.02.0016	4	53		01.60.20.0418	1
7		00.07.08.0420	1	30		00.99.00.0320	1	54		01.60.20.0451	1
8		00.41.00.0073	3	31		00.32.03.0040	1	55		01.60.20.0417	1
9		00.41.00.0074	4	32		01.40.00.2790	2	56		00.75.00.0042	1
10		00.41.00.0071	1	33		00.26.05.0060	3	57		00.29.10.0030	2
11		00.41.00.0060	5	34		00.92.05.1170	2	58		00.89.10.3000	1
12		00.32.03.0070	2	35		00.68.02.0030	2	59		00.91.04.0080	3
13		00.41.00.0115	1	36		00.26.04.0040	5	60		00.68.03.0010	3
15		00.41.00.0826	1	37		00.92.03.1070	3	61		00.26.04.0020	3
16		00.41.00.0116	1	38		00.41.00.0253	1	62		00.41.20.0064	1
17		00.41.00.0794	1	39		00.41.00.0124	1	63		00.54.10.0090	1
18		00.41.00.0868	1	40		00.41.00.0120	1	64		01.30.20.0024	1
19		00.41.20.0061	2	41		00.55.01.0390	1	65		00.41.00.0876	2
20		00.41.20.0073	1	42		00.29.01.0075	1	66	mt	00.07.05.0022	1,5
21		00.41.20.0063	1	43		00.90.06.0060	1	67		00.54.10.0027	1
22		00.41.20.0078	1	44		00.40.00.0500	1	68		01.50.20.0028	1
23		00.41.20.0053	1	45		00.75.00.0140	1	69		00.41.20.0141	1
24		00.41.20.0064	1	46		00.32.20.0011	1	90		00.32.20.0010	1
25		00.41.20.0062	1	47		00.32.20.0012	1				

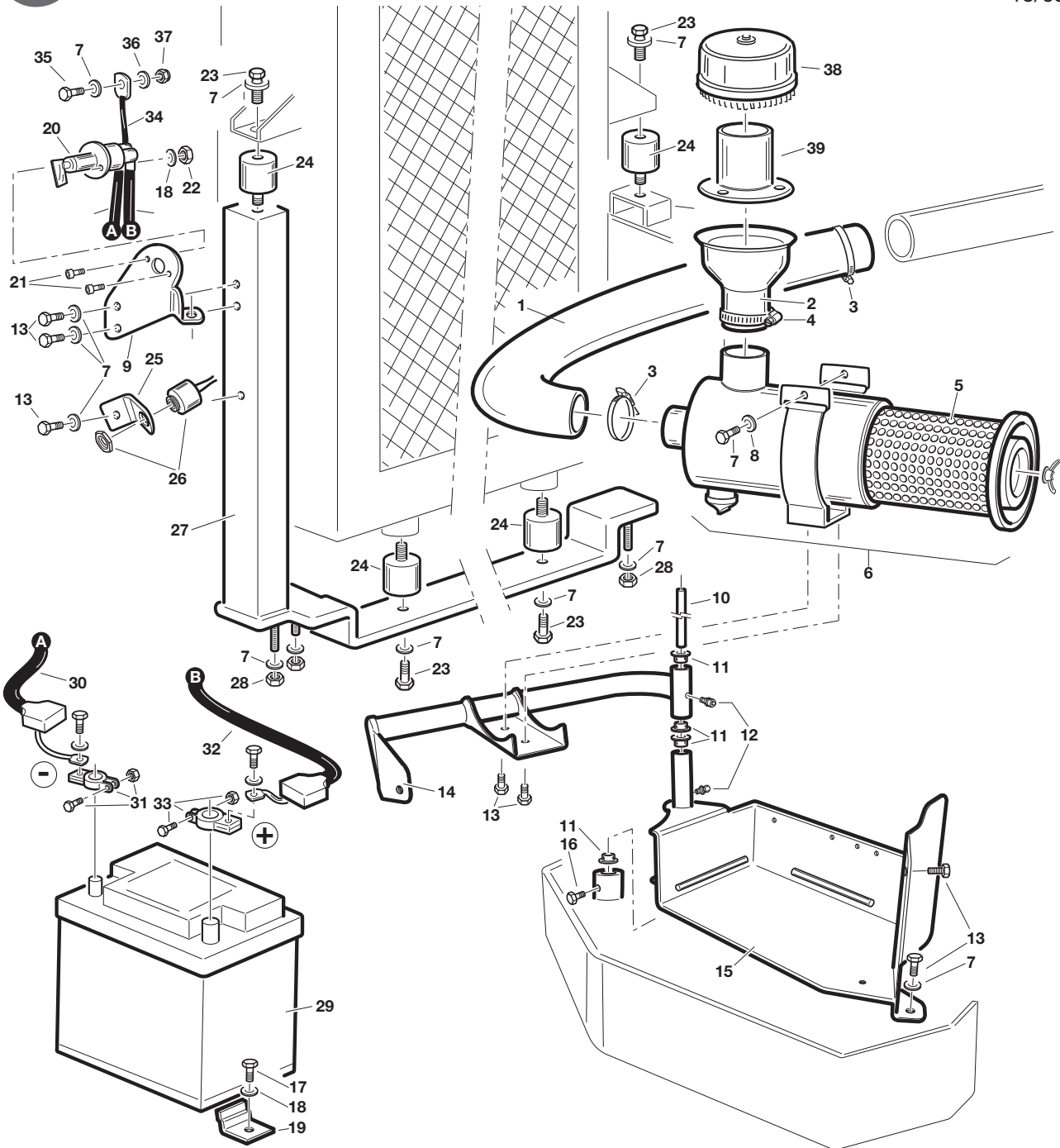

Ref.	Leg.	Code	Q.ty	Ref.	Leg.	Code	Q.ty	Ref.	Leg.	Code	Q.ty
1		00.89.13.0051	1	14		01.50.20.0069	1	27		01.50.20.0067	1
2		00.07.07.0330	1	15		01.50.20.0068	1	28		00.26.04.0060	3
3		00.29.02.0060	2	16		00.92.03.1140	1	29		00.09.00.0040	1
4		00.29.02.0070	1	17		00.92.03.1070	1	30		00.40.00.0287	1
5		00.32.03.0060	1	18		00.68.01.0020	3	31		00.40.00.0293	1
6		00.55.01.0410	1	19		01.60.20.0069	1	32		00.40.00.0286	1
7		00.68.01.0030	13	20		00.40.00.2090	1	33		00.40.00.0292	1
8		00.92.05.1110	1	21		00.92.03.1090	2	34		00.40.00.0288	1
9		00.60.20.0367	1	22		00.26.05.0040	2	35		00.92.05.1081	1
10		01.40.20.0062	1	23		00.92.05.1040	4	36		00.68.02.0050	1
11		01.50.00.0670	4	24		00.74.03.0070	4	37		00.26.03.0060	1
12		00.42.00.0010	2	25		01.50.00.5520	1	38		00.32.03.0190	1
13		00.92.05.1070	6	26		00.40.00.0221	1	39		01.50.20.0013	1

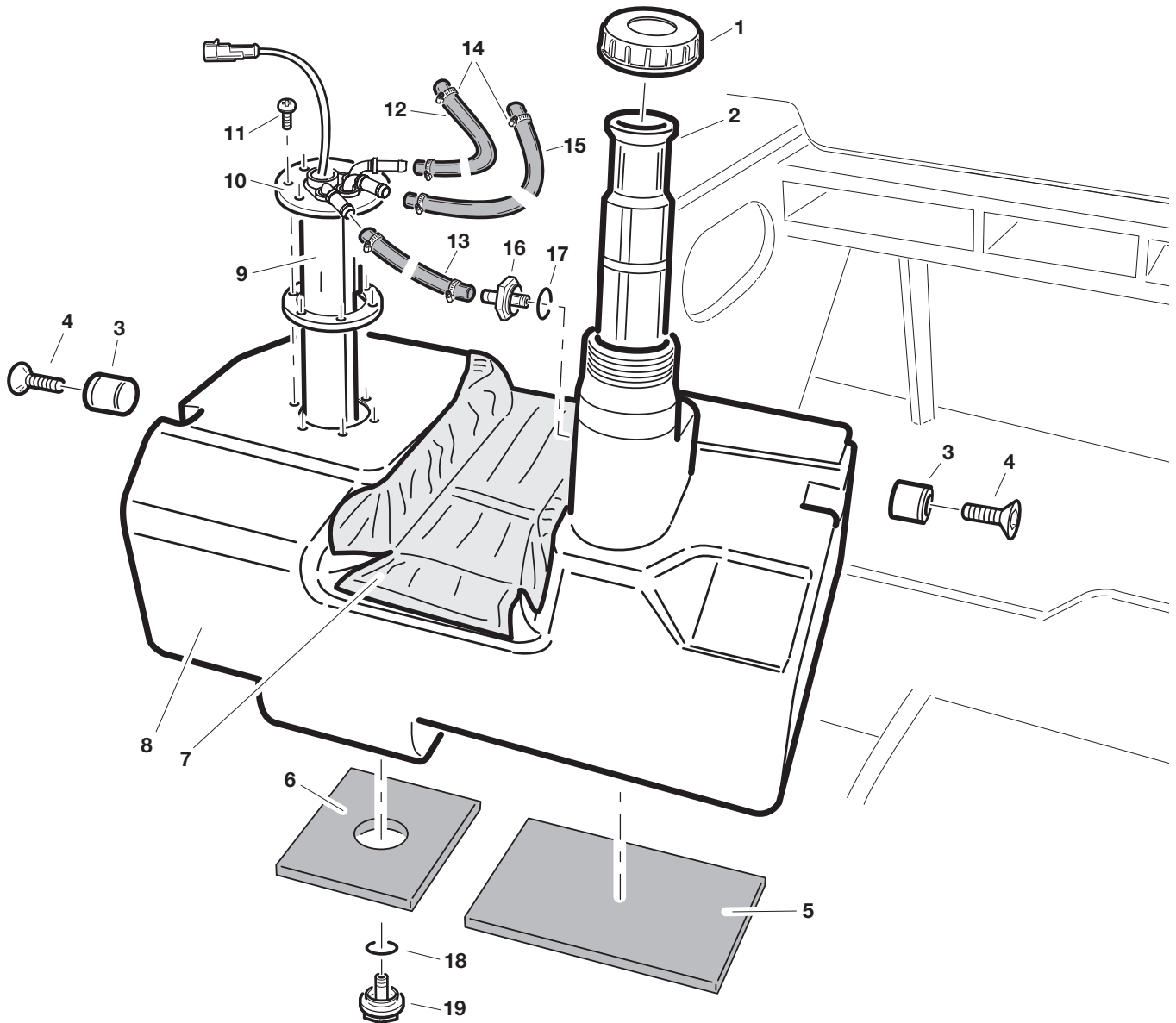

Ref.	Leg.	Code	Q.ty	Ref.	Leg.	Code	Q.ty
1		00.75.00.0012	1	11		00.94.06.3050	6
2		00.75.00.0013	1	12		00.89.01.0000	2,0m
3		00.74.00.4131	2	13		00.89.01.0000	0,35m
4		00.95.05.0060	2	14		00.29.02.0016	6
5		00.07.05.0010	1	15		00.89.02.0000	1
6		00.07.05.0011	1	16		00.75.00.0035	1
7		00.07.09.0360	1	17		00.06.10.0202	1
8		00.75.20.0010	1	18		00.06.10.0154	1
9		00.07.01.0170	1	19		00.75.00.0036	1
10		00.40.00.2290	1				

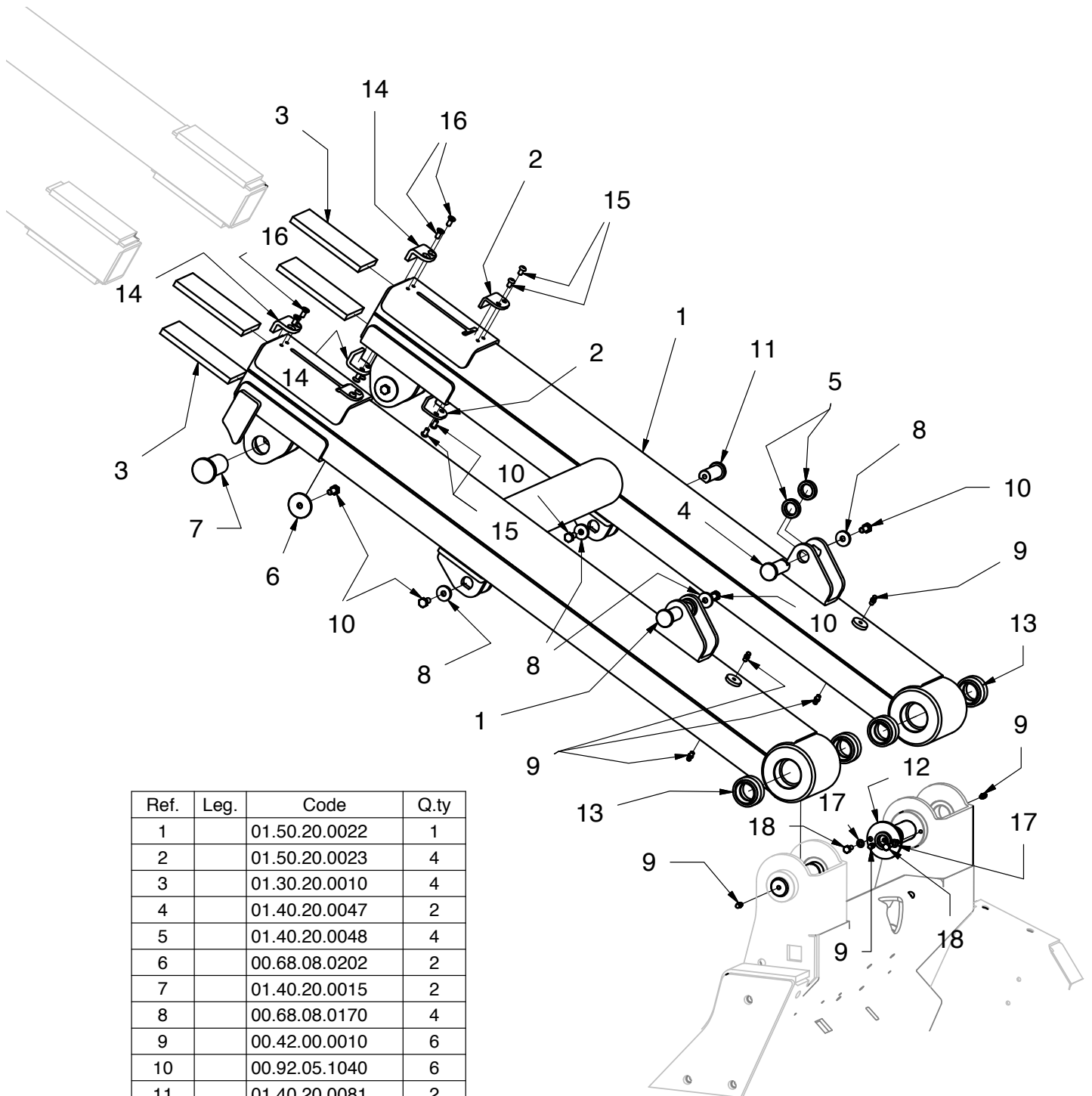

Ref.	Leg.	Code	Q.ty
1		01.50.20.0022	1
2		01.50.20.0023	4
3		01.30.20.0010	4
4		01.40.20.0047	2
5		01.40.20.0048	4
6		00.68.08.0202	2
7		01.40.20.0015	2
8		00.68.08.0170	4
9		00.42.00.0010	6
10		00.92.05.1040	6
11		01.40.20.0081	2
12		01.50.20.0096	2
13		00.78.03.2100	4
14		01.60.20.0460	4
15		00.90.04.3030	8
16		00.95.04.0030	8
17		00.68.01.0020	4
18		00.92.03.1040	4

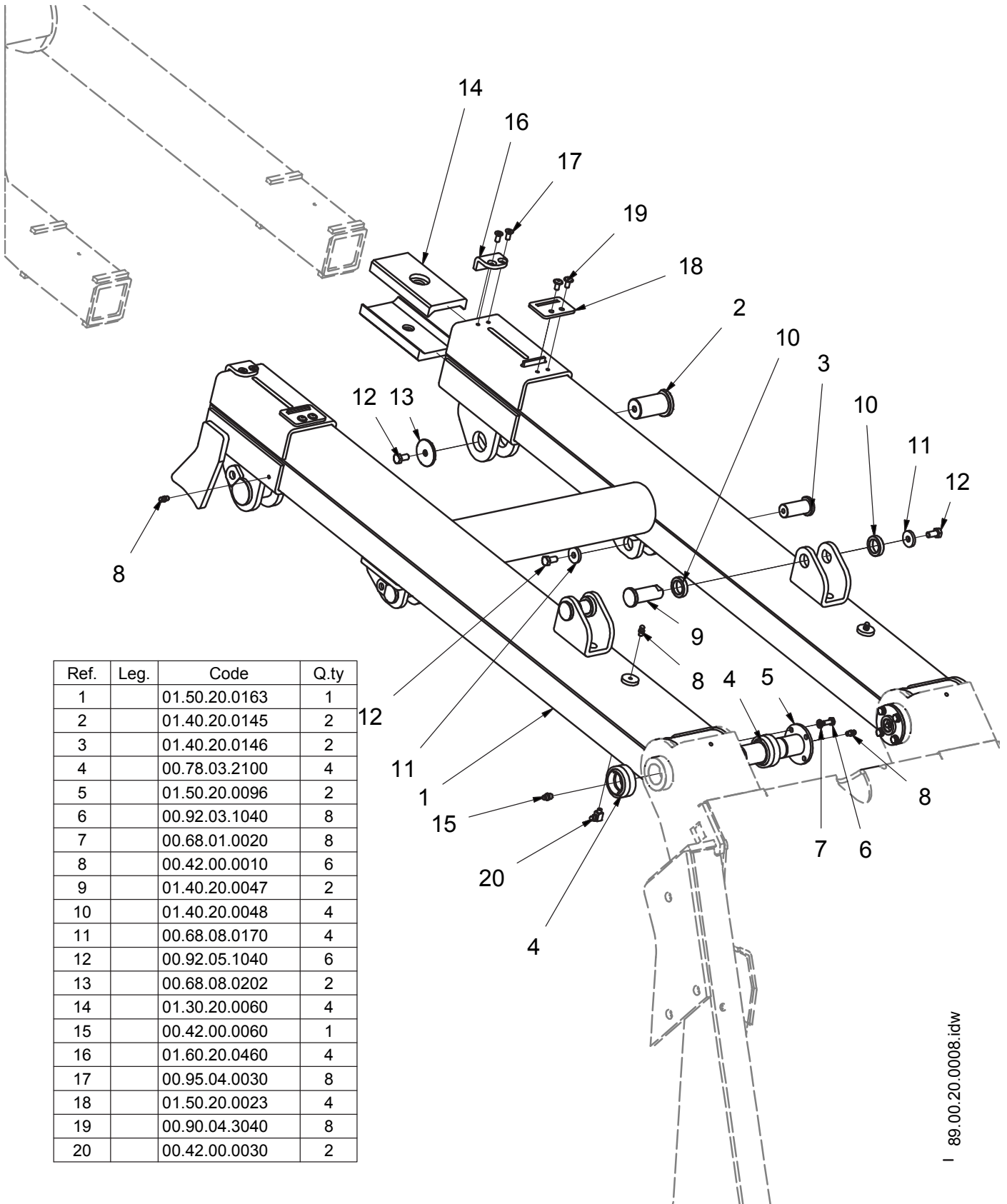

Ref.	Leg.	Code	Q.ty
1		01.50.20.0163	1
2		01.40.20.0145	2
3		01.40.20.0146	2
4		00.78.03.2100	4
5		01.50.20.0096	2
6		00.92.03.1040	8
7		00.68.01.0020	8
8		00.42.00.0010	6
9		01.40.20.0047	2
10		01.40.20.0048	4
11		00.68.08.0170	4
12		00.92.05.1040	6
13		00.68.08.0202	2
14		01.30.20.0060	4
15		00.42.00.0060	1
16		01.60.20.0460	4
17		00.95.04.0030	8
18		01.50.20.0023	4
19		00.90.04.3040	8
20		00.42.00.0030	2

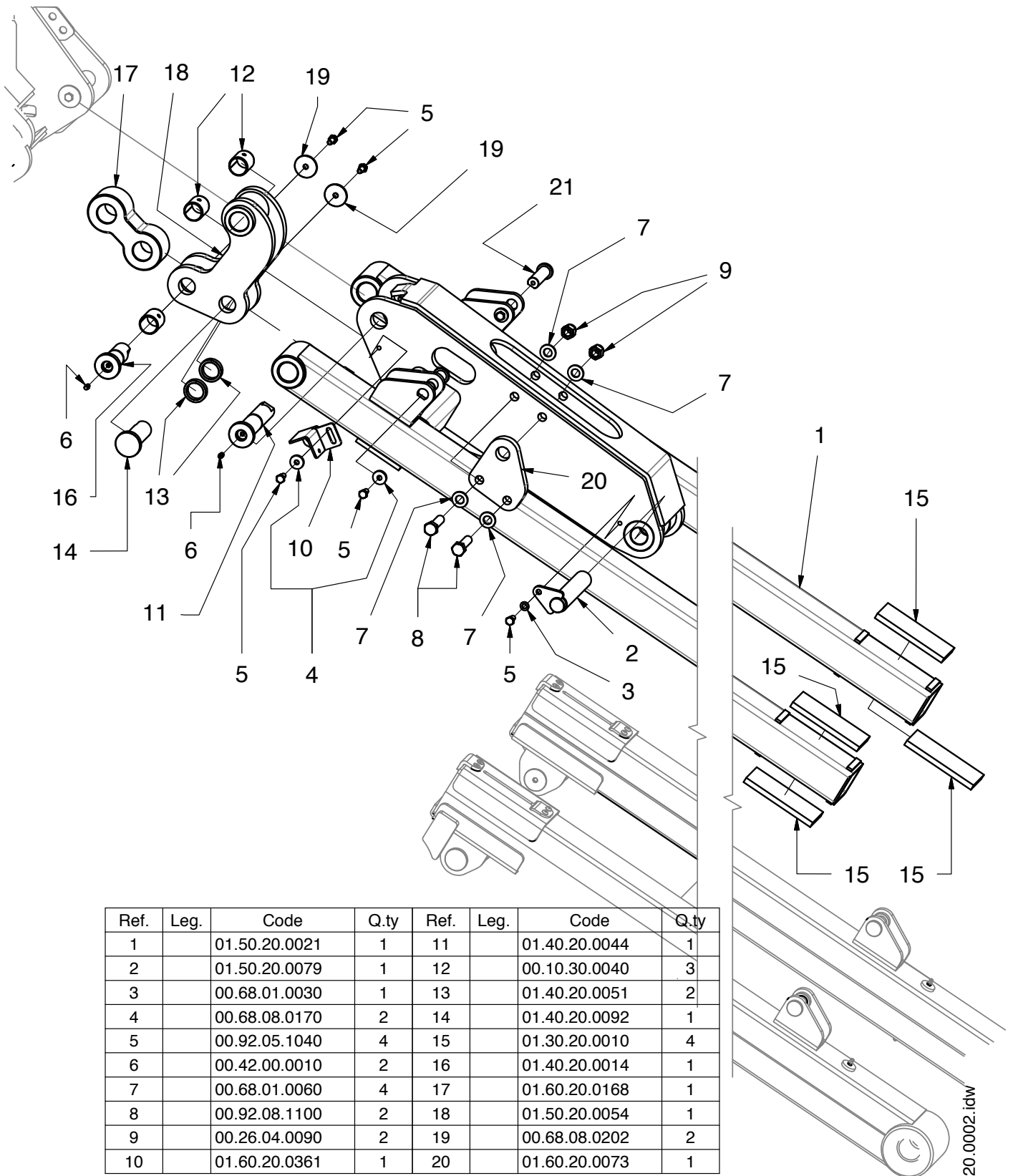

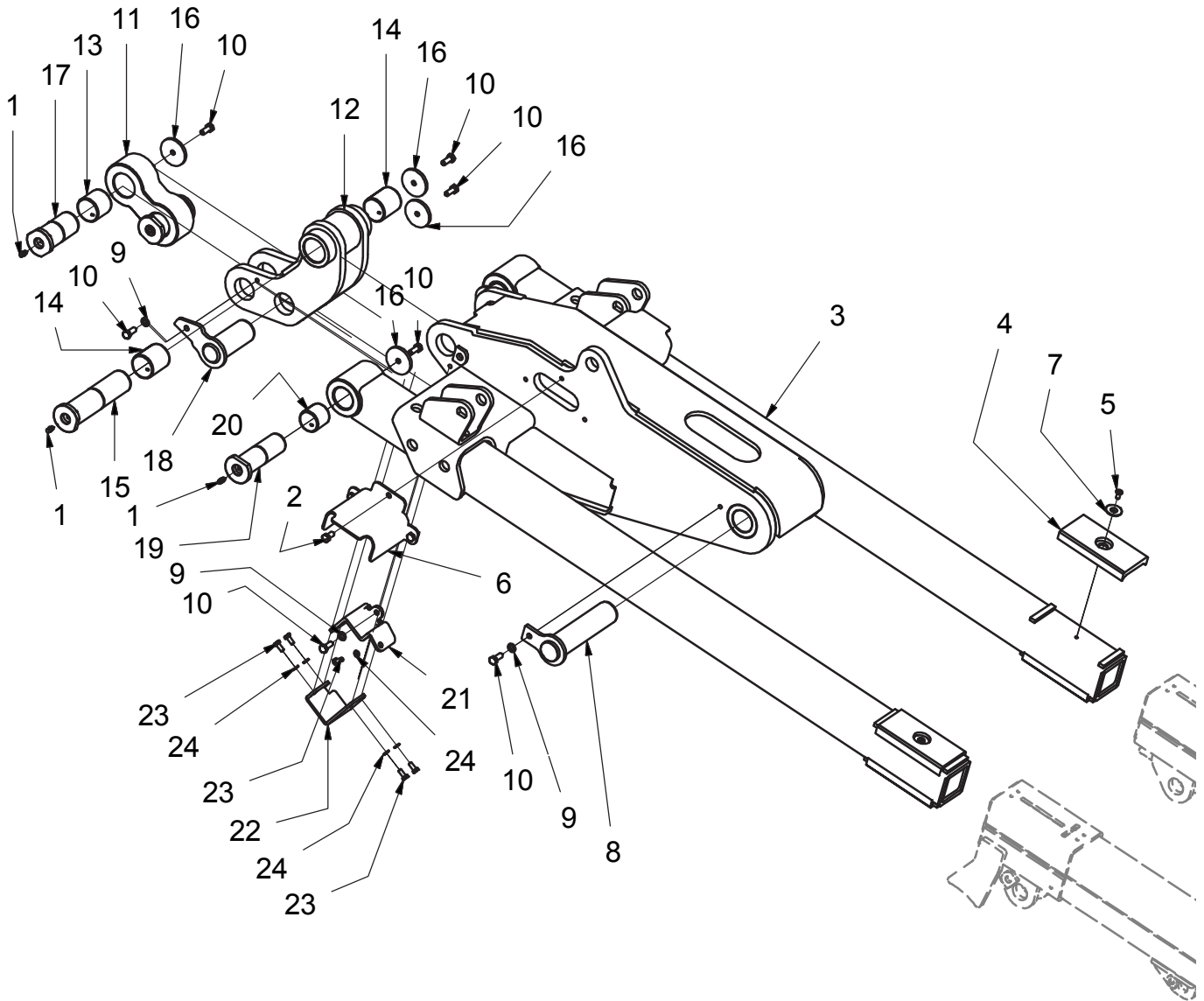

Ref.	Leg.	Code	Q.ty	Ref.	Leg.	Code	Q.ty
13		01.30.30.0050	2	1		00.42.00.0010	5
14		01.30.30.0051	2	2		00.92.05.1040	6
15		01.40.20.0139	1	3		01.50.20.0162	1
16		00.68.08.0205	6	4		01.30.20.0060	4
17		01.40.20.0141	2	5		00.95.04.0030	4
18		01.50.20.0266	1	6		01.60.20.0816	2
19		01.40.20.0143	2	7		01.40.20.0211	4
20		01.10.30.0035	4	8		01.50.20.0169	1
21		01.50.20.0277	1	9		00.68.01.0030	3
22		01.60.20.0867	1	10		00.92.05.1070	9
23		00.92.03.1040	5	11		01.60.20.0722	1
24		00.68.01.0020	5	12		01.50.20.0164	1

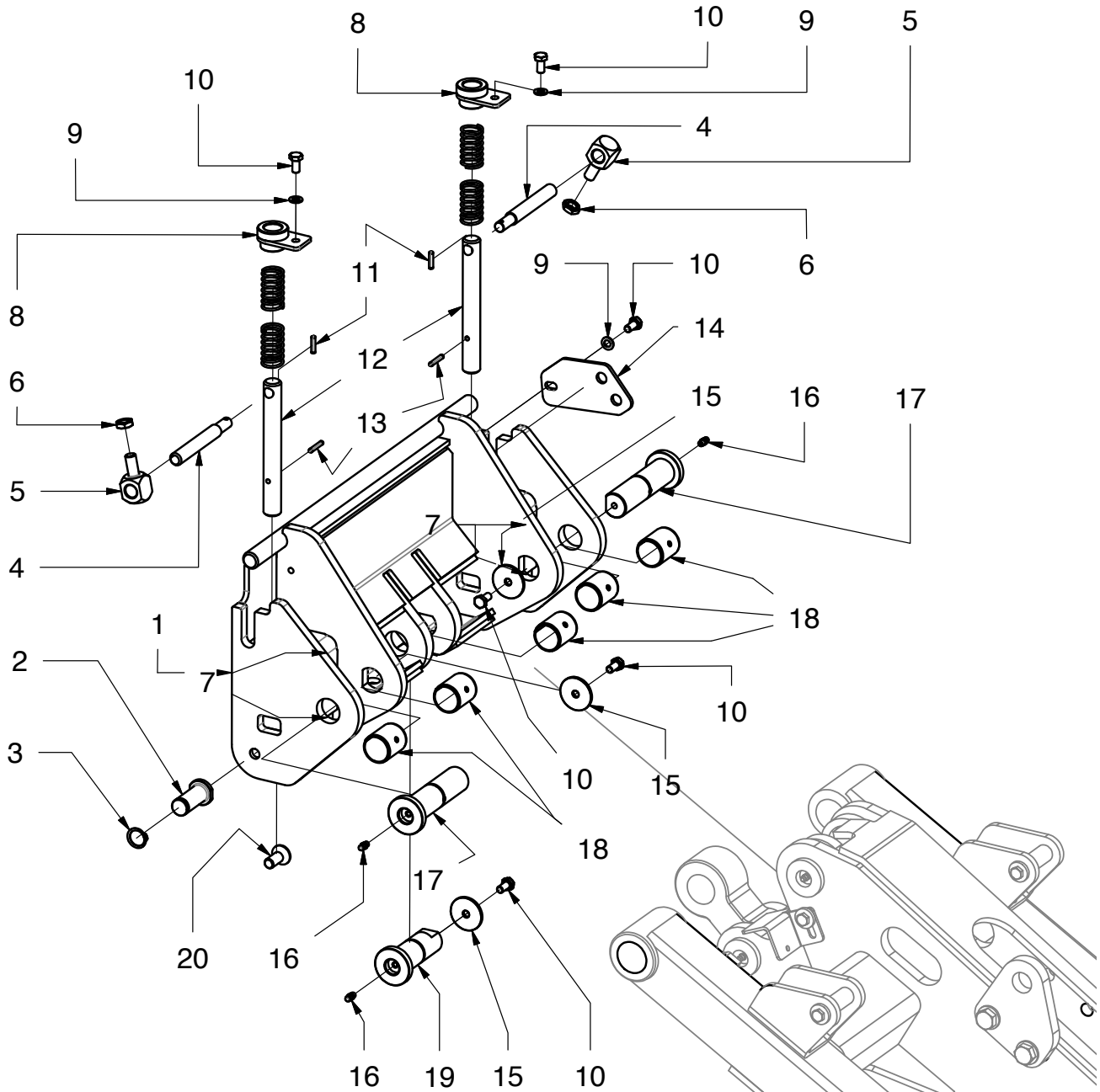

Ref.	Leg.	Code	Q.ty	Ref.	Leg.	Code	Q.ty
1		01.50.20.0030	1	11		00.83.11.1020	2
2		01.40.20.0076	2	12		01.40.20.0039	2
3		00.03.00.0160	2	13		00.83.11.1026	2
4		01.40.20.0040	2	14		01.60.20.0026	1
5		01.40.20.0075	2	15		00.68.08.0202	3
6		00.26.03.0090	2	16		00.42.00.0010	3
7		00.47.00.0230	4	17		01.40.20.0072	2
8		01.50.20.0055	2	18		00.10.30.0040	5
9		00.68.01.0030	3	19		01.40.20.0014	1
10		00.92.05.1040	5	20		00.95.07.0040	2

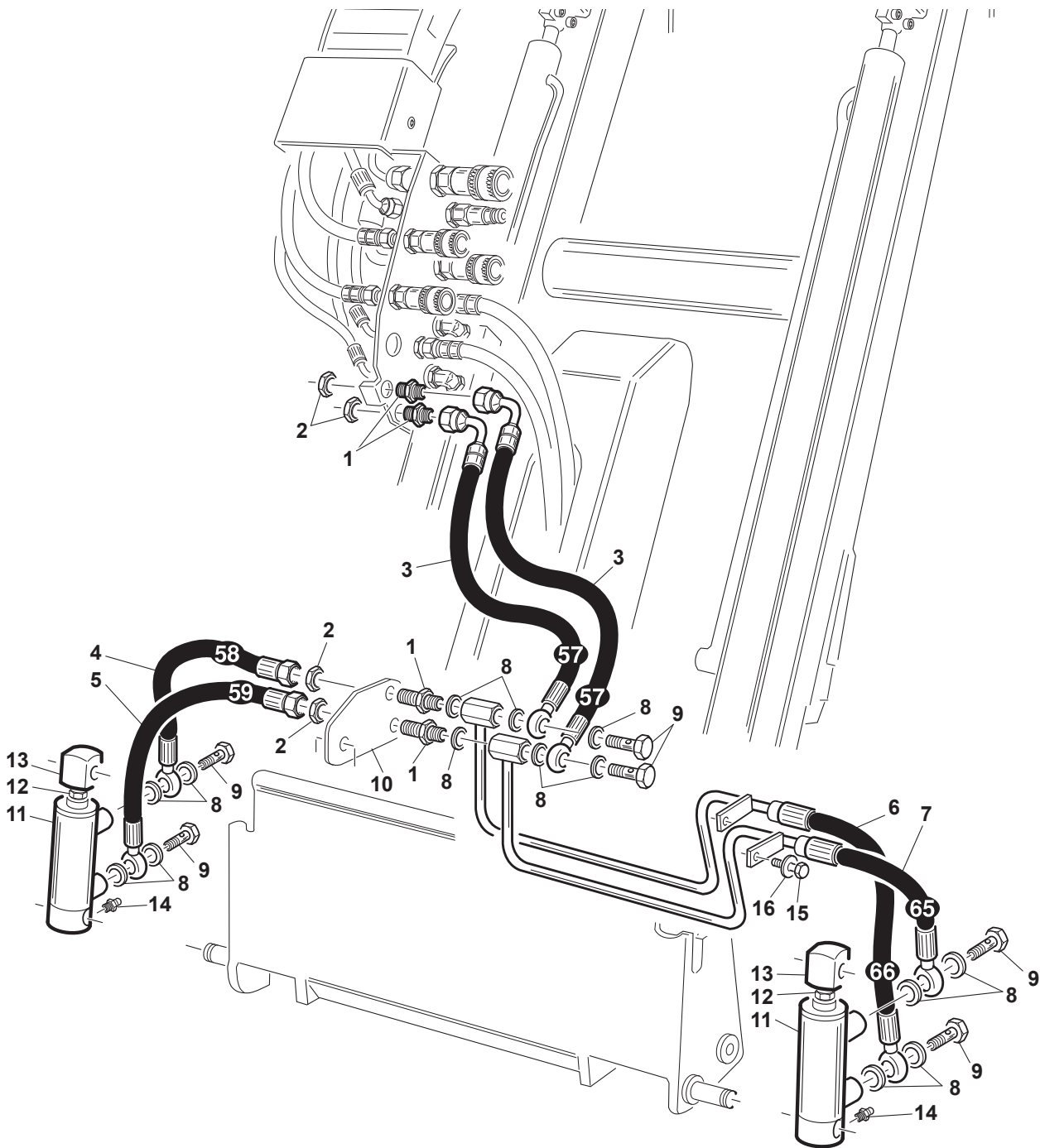

Ref.	Leg.	Code	Q.ty	Ref.	Leg.	Code	Q.ty	Ref.	Leg.	Code	Q.ty
1		00.41.00.0360	4	9		00.41.00.0120	6	17		00.58.20.0012	1
2		00.41.00.0370	4	10		01.60.20.0026	1	18		00.41.00.0250	2
3		00.41.20.0066	2	11		00.58.20.0015	2	19		00.41.00.0070	4
4		00.41.20.0067	1	12		00.26.03.0090	2	20		00.41.00.0242	1
5		00.41.20.0068	1	13		00.40.20.0075	2	21		00.41.20.0069	1
6		00.41.20.0075	1	14		00.42.00.0010	3	22		00.41.20.0070	1
7		00.41.20.0074	1	15		00.92.05.1080	2	23		00.41.00.0361	2
8		00.41.00.0060	14	16		00.68.02.0050	2	24		00.41.00.0371	2

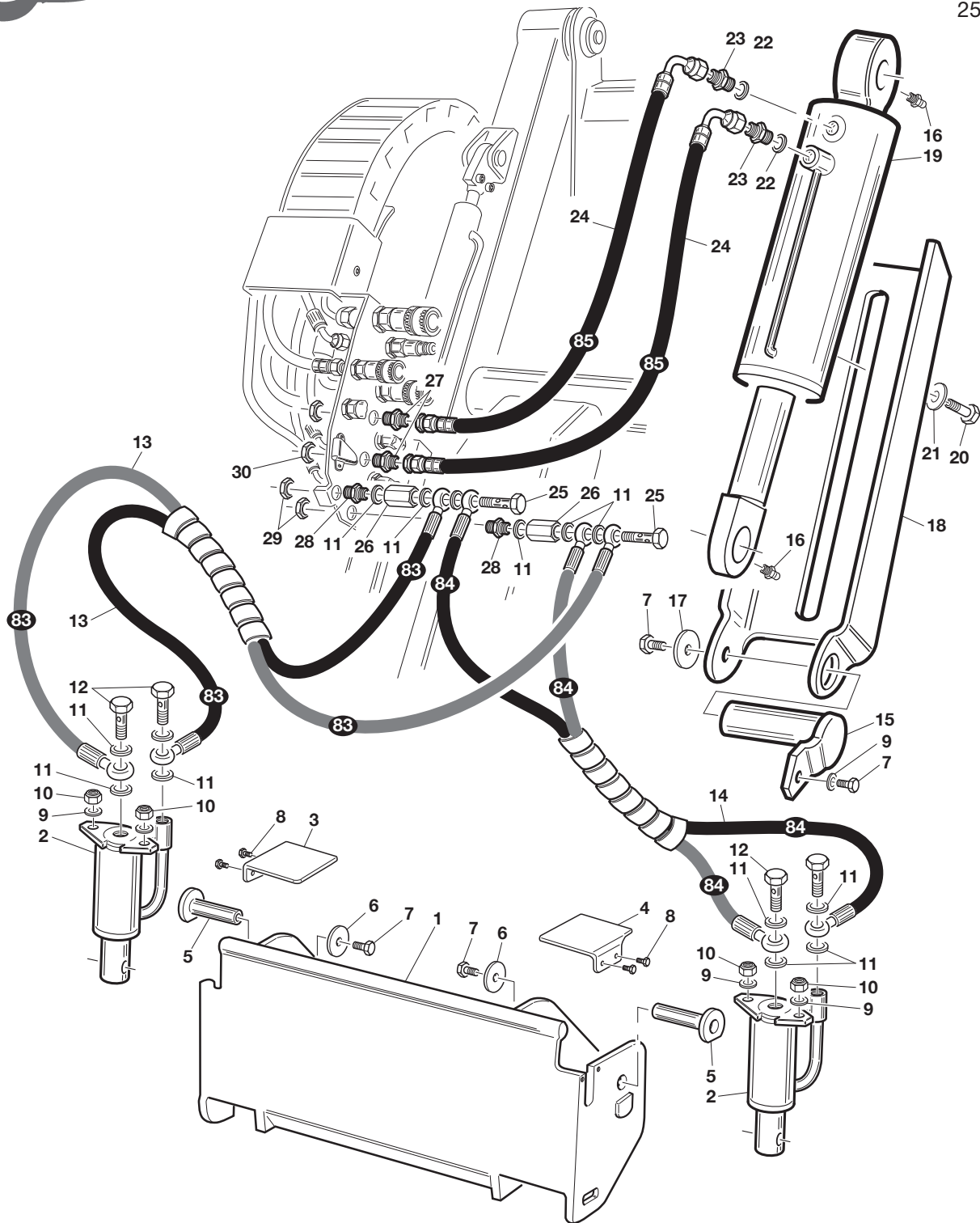

Ref.	Leg.	Code	Q.ty	Ref.	Leg.	Code	Q.ty	Ref.	Leg.	Code	Q.ty
1		01.50.20.0165	1	11		00.41.00.1292	16	21		00.68.02.0070	1
2		00.58.20.0024	2	12		00.41.00.0121	4	22		00.41.00.1290	2
3	DX	01.60.20.0811	1	13		00.41.20.0136	2	23		00.41.00.0110	2
4	SX	01.60.20.0808	1	14		00.41.20.0137	2	24		00.41.20.0138	2
5		01.40.20.0143	2	15		01.50.20.0266	1	25		00.41.00.0124	2
6		00.68.02.0202	2	16		00.42.00.0010	2	26		00.41.00.3671	2
7		00.92.05.1040	3	17		00.68.08.0205	1	27		00.41.00.0361	2
8		00.90.04.3040	5	18		01.60.20.0817	1	28		00.41.00.0360	2
9		00.68.01.0030	5	19		00.58.20.0022	1	29		00.41.00.0370	2
10		00.26.04.0060	4	20		00.92.06.1060	1	30		00.41.00.0371	2

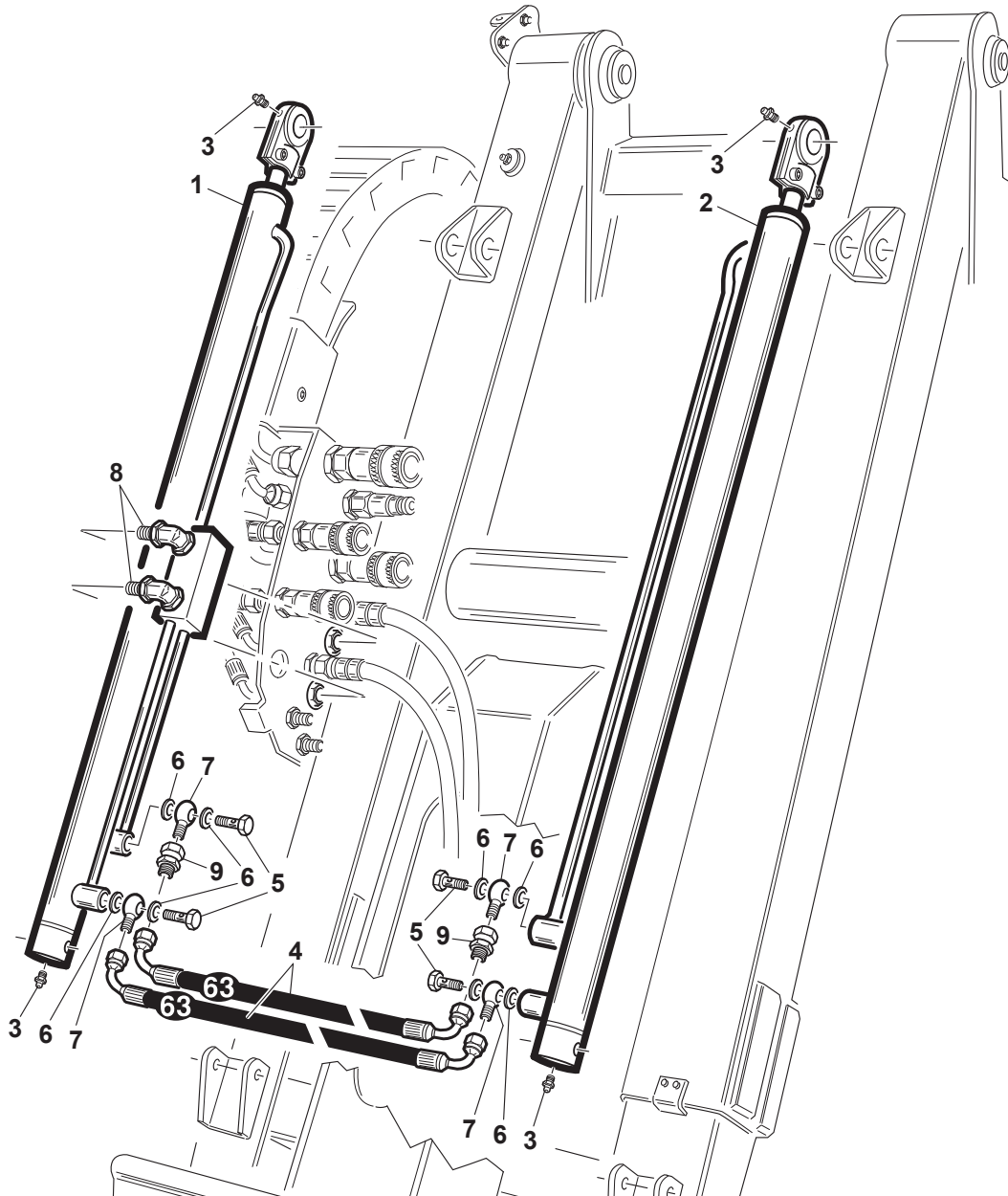

Ref.	Leg.	Code	Q.ty
1	DX	00.58.20.0016	1
2	SX	00.58.20.0010	1
3		00.42.00.0010	4
4		00.41.20.0072	2
5		00.41.20.0120	4
6		00.41.00.0060	8
7		00.41.00.0240	4
8		00.41.00.0875	2
9		00.41.00.2821	2

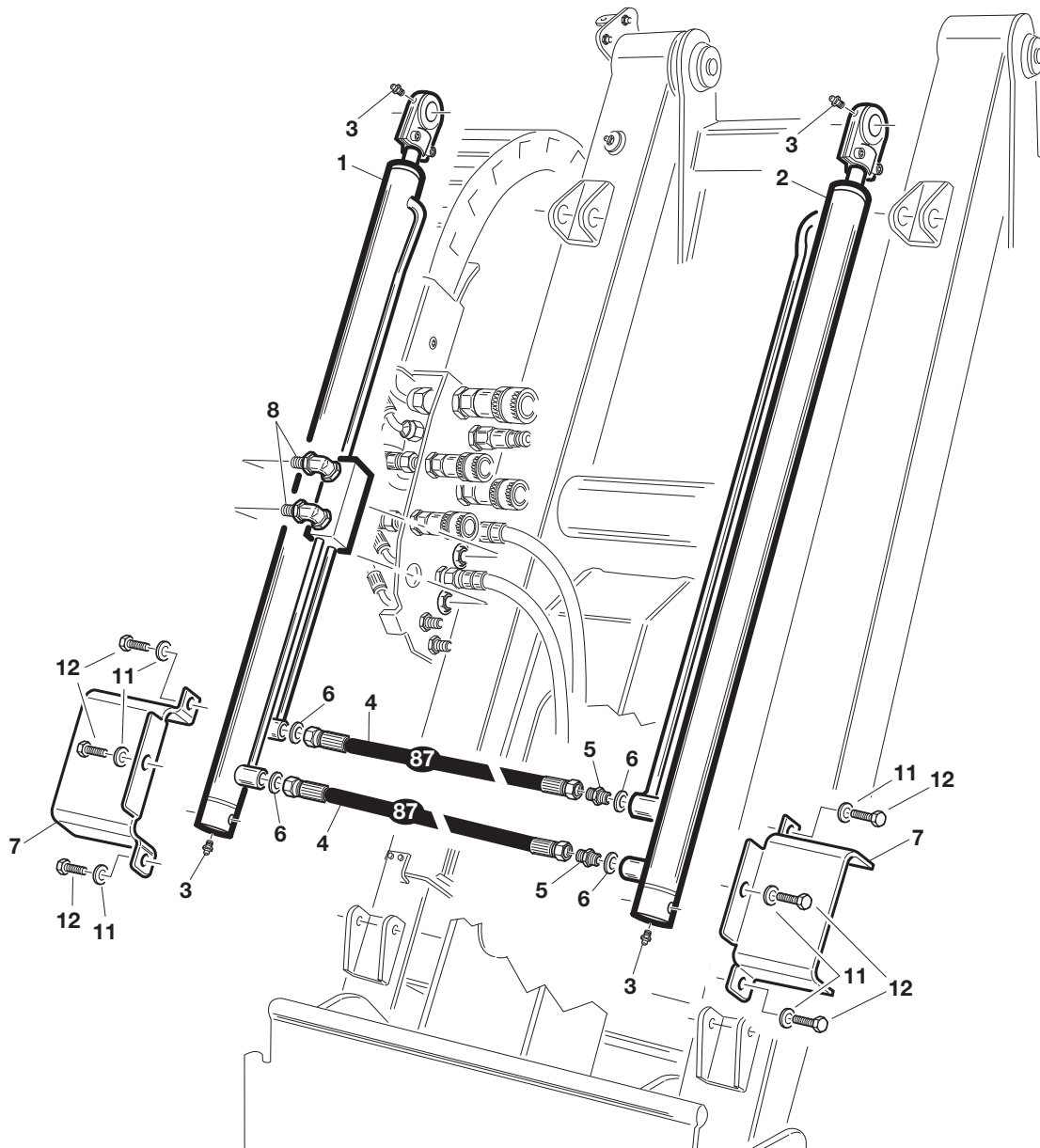

Ref.	Leg.	Code	Q.ty
1	DX	00.58.20.0016	1
2	SX	00.58.20.0010	1
3		00.42.00.0010	4
4		00.41.20.0151	2
5		00.41.00.0450	2
6		00.41.00.1292	4
7		01.60.20.0816	2
8		00.41.00.0875	2
11		00.68.01.0030	6
12		00.92.05.1040	6



**Gianni
Ferrari**

1H57083

Tav. 09 - TurboLoader

M220 - M280 - M360

11/01/2012

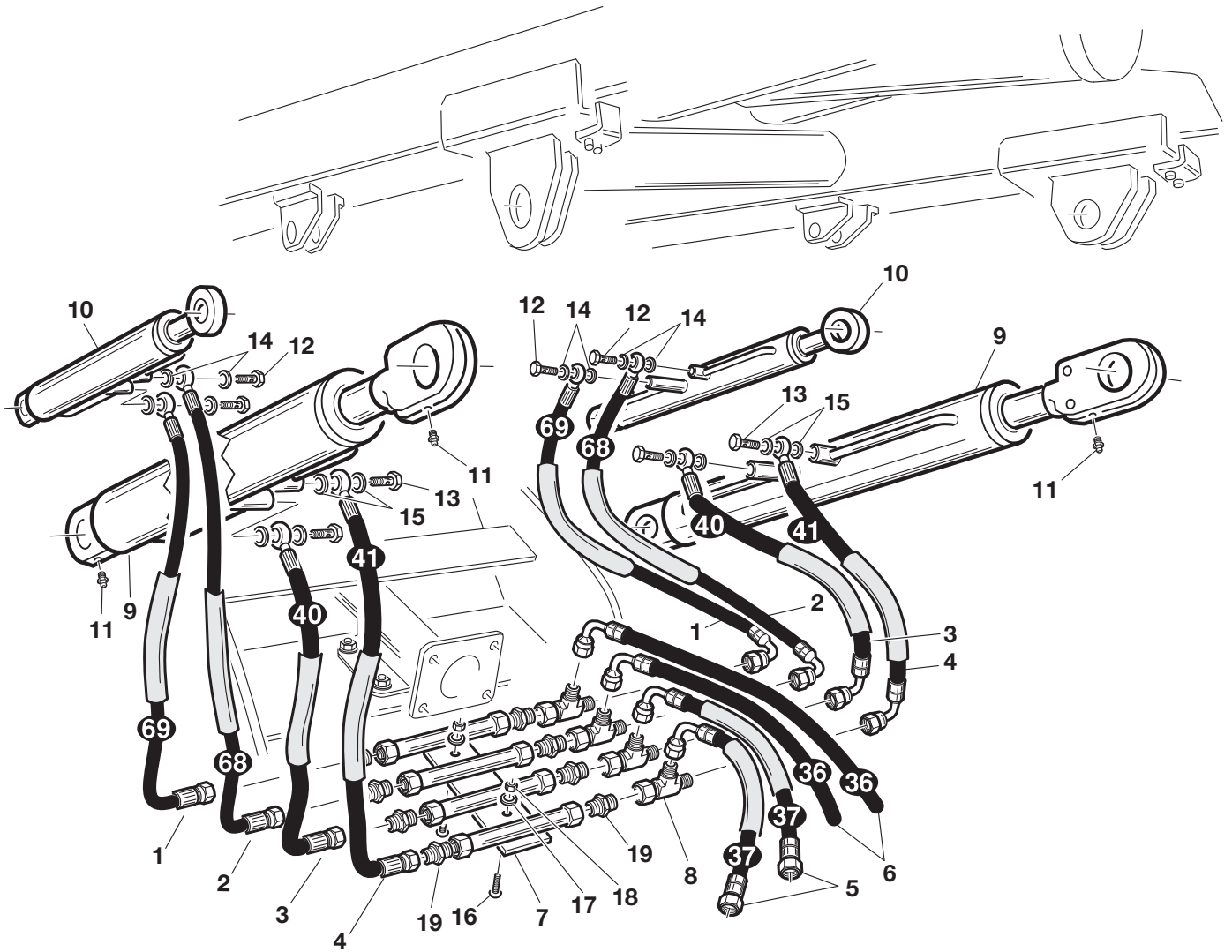

Ref.	Leg.	Code	Q.ty	Ref.	Leg.	Code	Q.ty
1		00.41.20.0080	2	11		00.42.00.0010	4
2		00.41.20.0079	2	12		00.41.00.0120	4
3		00.41.20.0049	2	13		00.41.00.0250	4
4		00.41.20.0050	2	14		00.41.00.0060	8
5		00.41.20.0046	2	15		00.41.00.0070	8
6		00.41.20.0045	2	16		00.90.06.3100	2
7		01.50.20.0102	1	17		00.68.01.0030	2
8		00.41.00.0881	4	18		00.26.05.0060	2
9		00.58.20.0011	2	19		00.41.00.0092	8
10		00.58.20.0021	2				

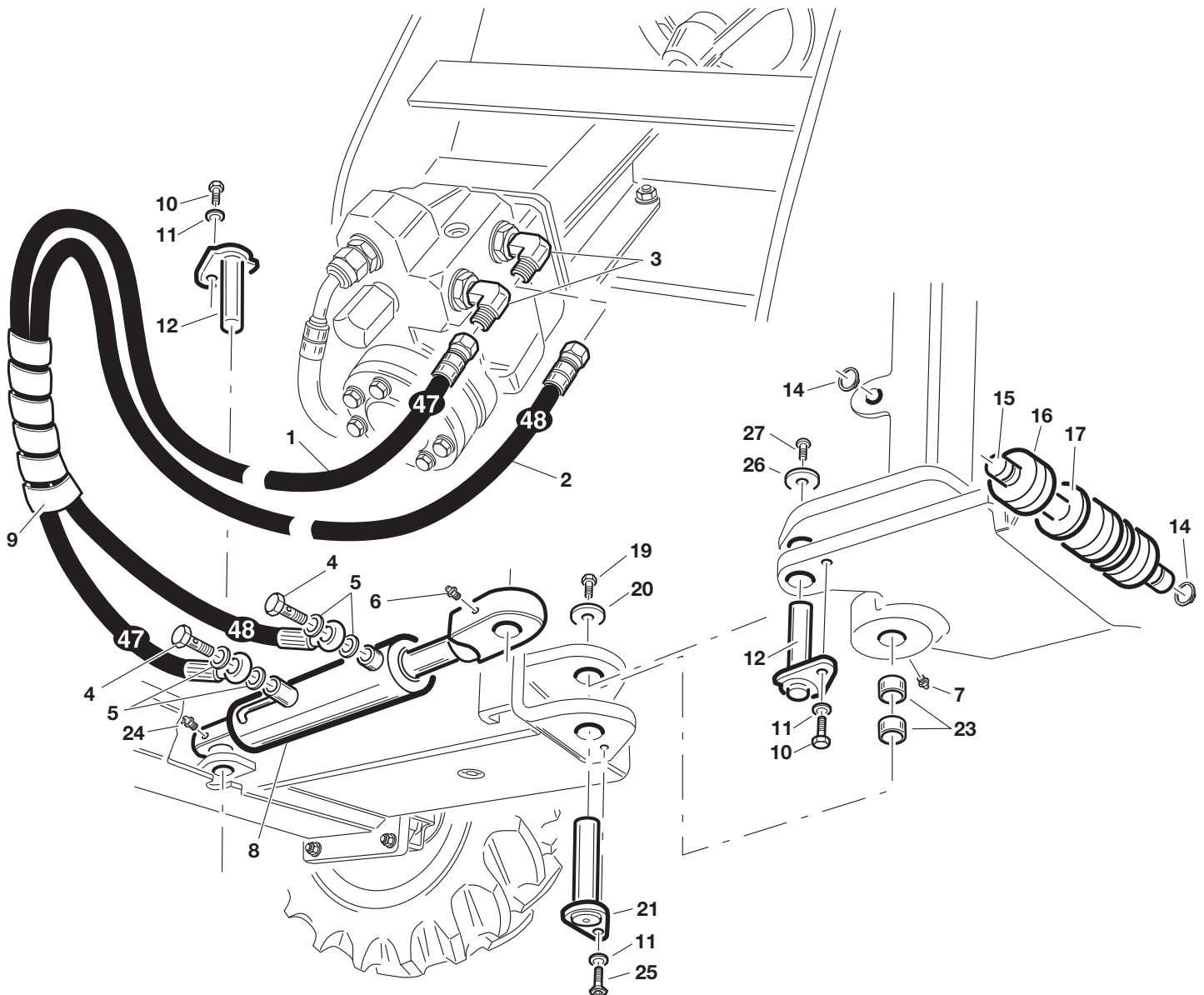

Ref.	Leg.	Code	Q.ty	Ref.	Leg.	Code	Q.ty
1		00.41.20.0056	1	15		01.40.20.0166	1
2		00.41.20.0057	1	16		01.30.00.0510	3
3		00.41.00.0875	2	17		00.68.08.0419	3
4		00.41.00.0280	2	19		00.92.06.1040	2
5		00.41.00.0070	4	20		00.68.08.0303	2
6		00.42.00.0010	1	21		01.50.20.0042	2
7		00.42.00.0010	2	22		00.95.05.0040	1
8		00.58.20.0013	1	23		00.10.35.0045	2
9		00.07.01.0184	0,15m	24		00.42.00.0030	1
10		00.92.05.1070	2	25		00.95.05.0020	1
11		00.68.01.0030	3	26		00.68.08.0202	1
12		01.50.20.0015	2	27		00.90.06.3060	1
14		00.03.00.0110	2				

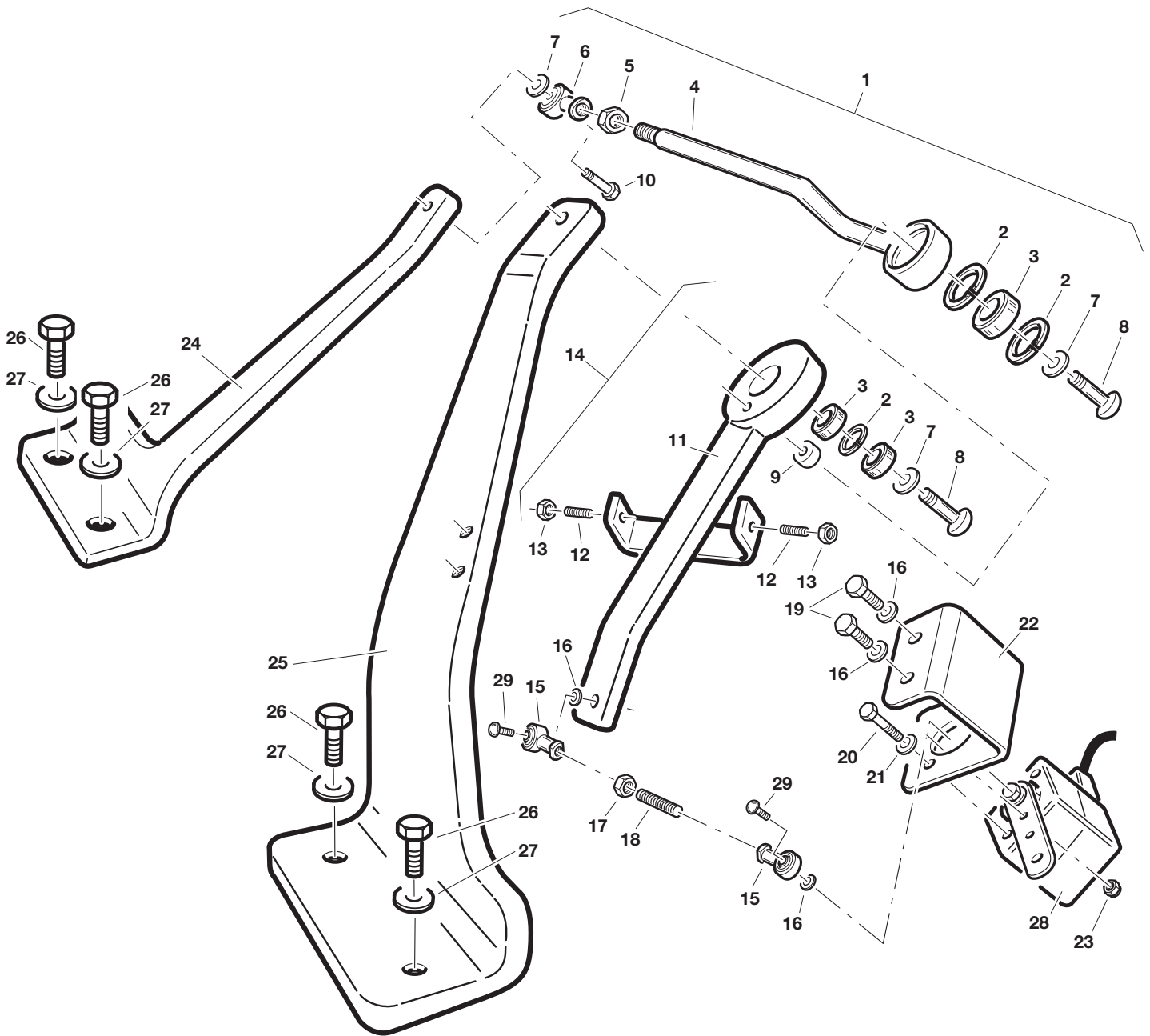

Ref.	Leg.	Code	Q.ty	Ref.	Leg.	Code	Q.ty	Ref.	Leg.	Code	Q.ty
1		01.90.20.0106	1	11		01.50.20.0100	1	21		00.68.01.0010	2
2		00.03.09.0026	3	12		00.96.05.0120	2	22		01.60.20.0379	1
3		00.22.00.0111	3	13		00.26.02.0060	2	23		00.26.05.0040	1
4		01.50.20.0101	1	14		01.90.20.0105	1	24		01.60.20.0275	1
5		00.26.03.0080	1	15		00.78.01.0010	2	25		01.60.20.0276	1
6		00.78.01.0012	1	16		00.68.01.0020	5	26		00.92.06.1080	4
7		00.68.01.0040	2	17		00.26.02.0040	1	27		00.68.01.0040	4
8		00.90.07.3120	2	18		00.96.04.0110	1	28		00.40.00.2518	1
9		01.40.20.0089	1	19		00.92.03.1040	2				
10		00.92.06.1080	1	20		00.92.02.1020	2				

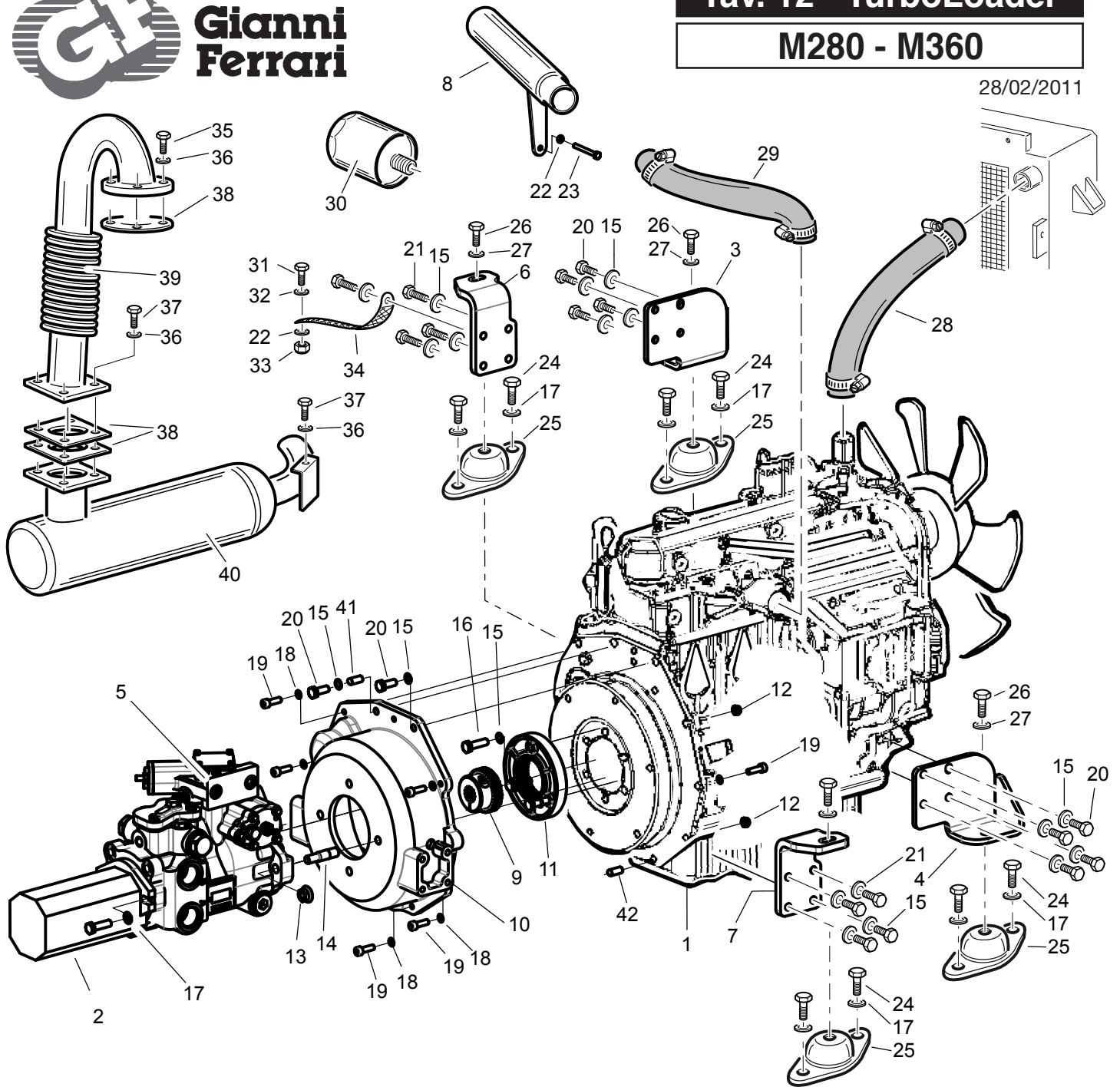

Ref.	Leg.	Code	Q.ty	Ref.	Leg.	Code	Q.ty	Ref.	Leg.	Code	Q.ty
1	1505	00.54.01.0040	1	15		00.68.12.0010	21	30		00.32.03.0050	1
1	1100	00.54.01.0030	1	16		00.92.06.3090	3	31		00.92.03.1110	1
2		00.41.00.3550	1	17		00.68.01.0040	10	32		00.68.03.0030	1
3		01.60.20.0099	1	18		00.68.12.0008	8	33		00.26.04.0040	1
4		01.60.20.0082	1	19		00.90.06.0100	8	34		00.40.00.0282	1
5		00.41.00.3540	1	20		00.92.06.3050	10	35		00.92.05.1070	4
6		01.60.20.0177	1	21		00.92.06.3081	8	36		00.68.01.0030	9
7		01.60.20.0180	1	22		00.68.01.0020	2	37		00.92.05.1110	5
8		01.50.20.0095	1	23		00.92.03.1160	1	38		00.55.01.0210	3
9		00.55.01.0843	1	24		00.92.06.1080	8	39		01.50.20.0075	1
10		00.55.01.0851	1	25		00.74.07.0020	4	40		00.46.20.0010	1
11		00.55.01.0852	1	26		00.92.07.1070	4	41		00.83.14.4016	1
12		00.26.05.0060	2	27		00.68.01.0050	4	42		00.83.14.0100	1
13		00.26.09.0070	2	28		00.89.14.0001	1				
14		01.40.20.0011	2	29		00.07.07.0322	1				

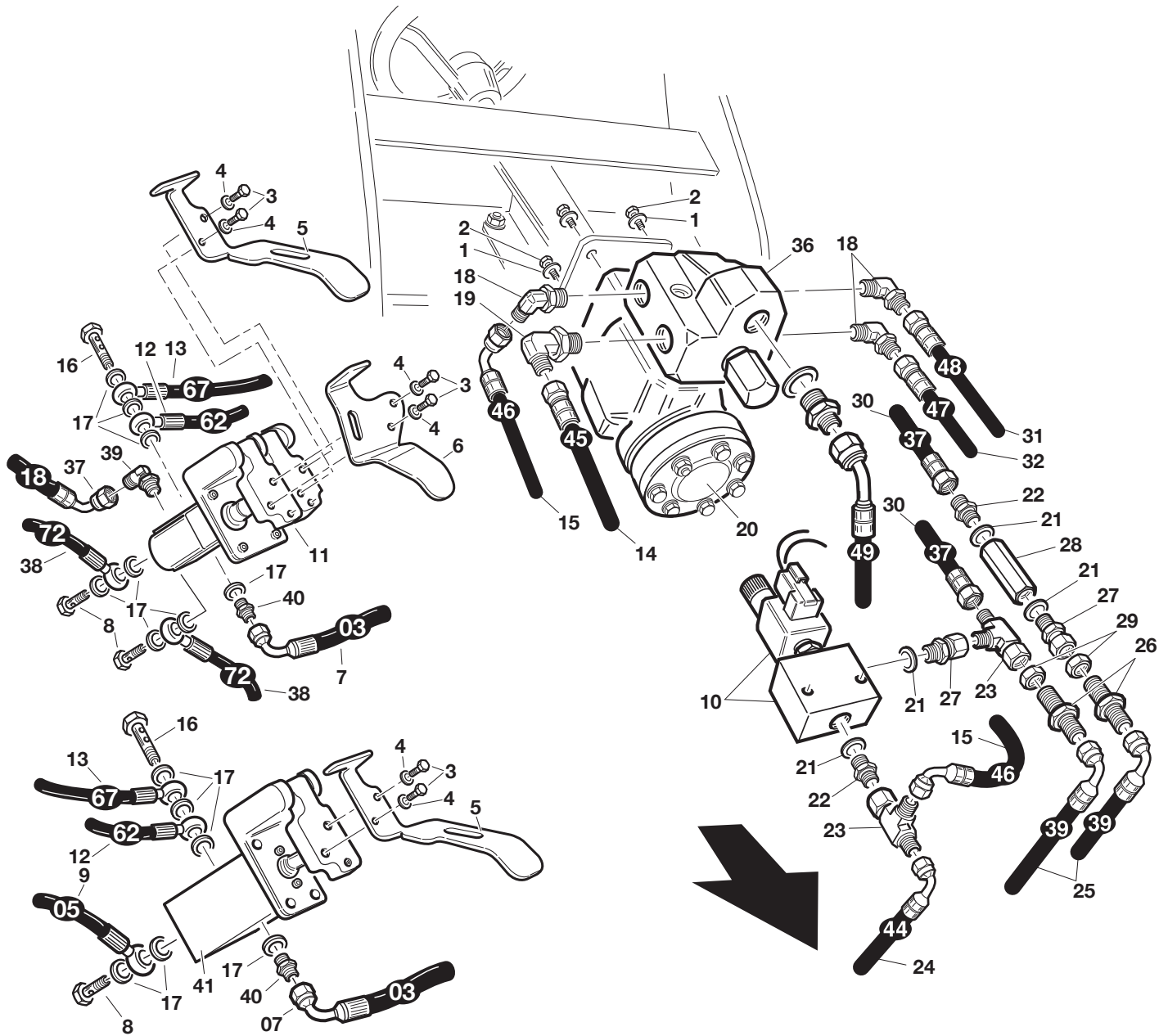

Ref.	Leg.	Code	Q.ty	Ref.	Leg.	Code	Q.ty	Ref.	Leg.	Code	Q.ty
1		00.68.12.0010	4	14		00.41.20.0054	1	28		00.41.00.0296	1
2		00.92.06.1060	4	15		00.41.20.0055	1	29		00.41.00.0371	2
3		00.92.03.1090	6	16		00.41.00.0124	2	30		00.41.20.0046	2
4		00.68.01.0020	6	17		00.41.00.0060	14	31		00.41.20.0057	1
5		01.60.20.0509	2	18		00.41.00.0875	3	32		00.41.20.0056	1
6		01.60.20.0510	1	19		00.41.00.0876	1	33		00.41.20.0058	1
7		00.41.20.0012	2	20		00.41.00.3560	1	34		00.41.00.0113	1
8		00.41.00.0120	3	21		00.41.00.0070	4	35		00.41.00.0071	1
9		00.41.20.0014	1	22		00.41.00.0110	2	36		00.41.00.3570	1
10		00.41.00.3580	1	23		00.41.00.0881	2	37		00.41.20.0027	1
11		00.41.00.3693	1	24		00.41.20.0053	1	38		00.41.20.0104	2
12		00.41.20.0078	1	25		00.41.20.0048	2	39		00.41.00.0873	1
13	06	00.41.20.0015	1	26		00.41.00.0361	2	40		00.41.00.0450	2
13	67	00.41.20.0118	1	27		00.41.00.2822	2	41		00.41.00.3690	1

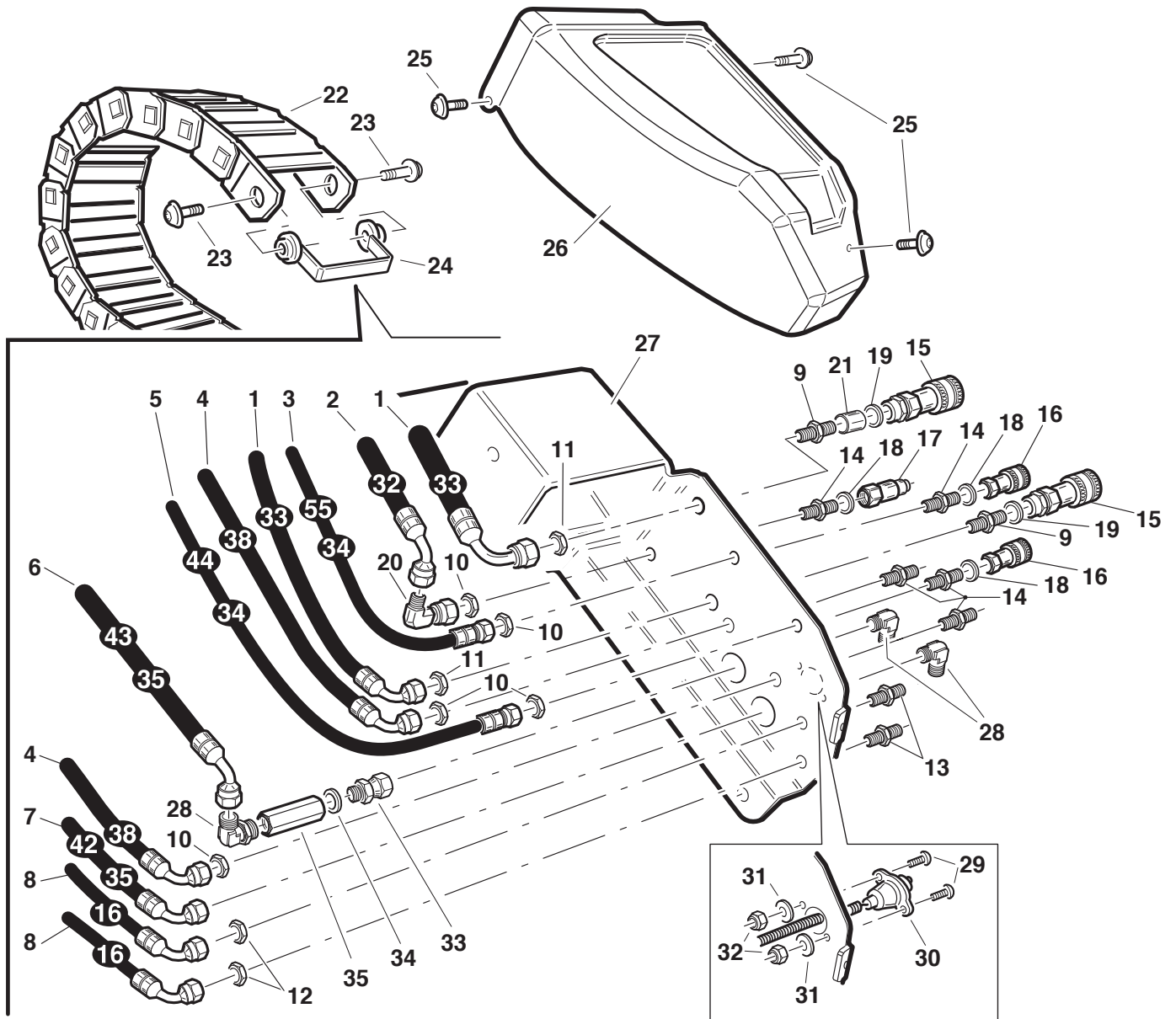

Ref.	Leg.	Code	Q.ty	Ref.	Leg.	Code	Q.ty	Ref.	Leg.	Code	Q.ty
1		00.41.20.0042	2	10		00.41.00.0371	4	23		00.90.06.3080	2
2		00.41.20.0041	1	11		00.41.00.0373	2	24		01.50.20.0027	1
3	55	00.41.20.0064	1	12		00.41.00.0370	2	25		01.90.04.3070	3
3	34	01.41.20.0043	1	13		00.41.00.0360	2	26		01.30.20.0012	1
4		00.41.20.0047	2	14		00.41.00.0361	5	27		01.50.20.0066	1
5	44	00.41.20.0043	1	15		00.41.00.0465	2	28		00.41.00.0875	3
5	34	01.41.20.0043	1	16		00.41.00.3762	2	29		00.91.04.0050	2
6	43	00.41.20.0052	1	17		00.41.00.3772	1	30		00.40.00.3000	1
6	35	01.41.20.0044	1	18		00.41.00.0070	4	31		00.68.01.0009	2
7	42	00.41.20.0051	1	19		00.41.00.1293	2	32		00.26.04.0020	2
7	35	01.41.20.0044	1	20		00.41.00.0871	2	33		00.41.00.2822	1
8		00.41.20.0025	2	21		01.40.20.0025	1	34		00.41.00.1290	1
9		00.41.00.0363	2	22		00.15.03.0001	1	35		00.41.00.0296	1

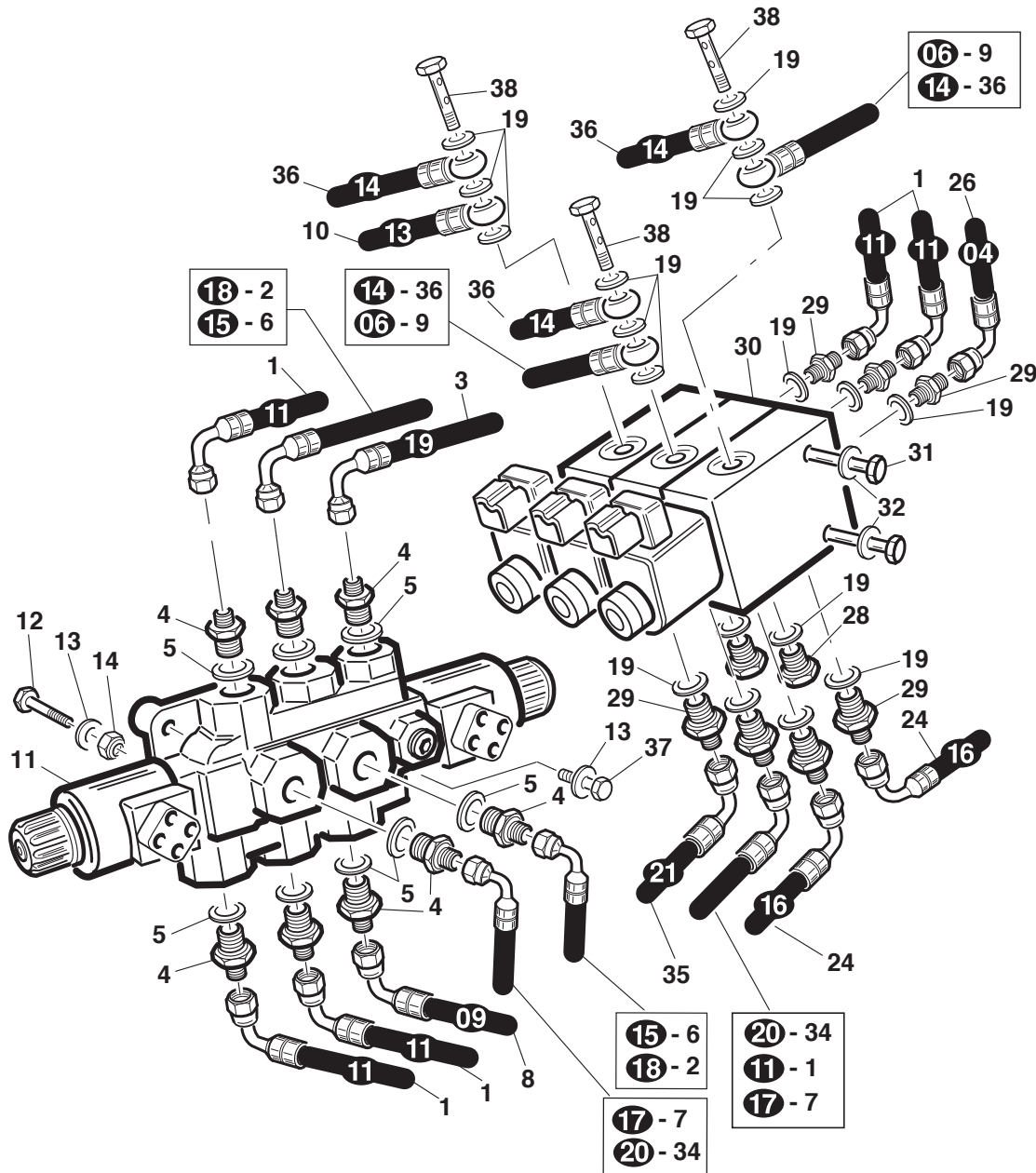

Ref.	Leg.	Code	Q.ty	Ref.	Leg.	Code	Q.ty	Ref.	Leg.	Code	Q.ty
1		00.41.20.0020	3	14		00.26.05.0060	3	27		00.41.00.2101	1
2		00.41.20.0027	1	15		00.41.20.0011	1	28		00.85.02.0002	2
3		00.41.20.0028	1	16		00.41.00.0874	1	29		00.41.00.0780	8
4		00.41.00.0781	8	17		00.41.20.0012	1	30		00.41.00.3420	3
5		00.41.00.0070	8	18		00.41.00.0450	1	31		00.92.03.0270	2
6		00.41.20.0024	1	19		00.41.00.0060	20	32		00.68.01.0020	2
7		00.41.20.0026	1	20		00.41.00.3660	1	34		00.41.20.0029	1
8		00.41.20.0018	1	21		00.90.06.3150	2	35		00.41.20.0030	1
9		00.41.20.0015	1	22		00.90.06.3100	2	36		00.41.20.0023	2
10		00.41.20.0022	1	23		00.41.20.0010	1	37		00.92.05.1120	1
11		00.41.00.3640	1	24		00.41.20.0025	2	38		00.41.00.0124	3
12		00.90.06.3130	1	25		00.41.20.0032	1	39		00.90.06.3100	2
13		00.68.01.0030	4	26		00.41.20.0013	1				

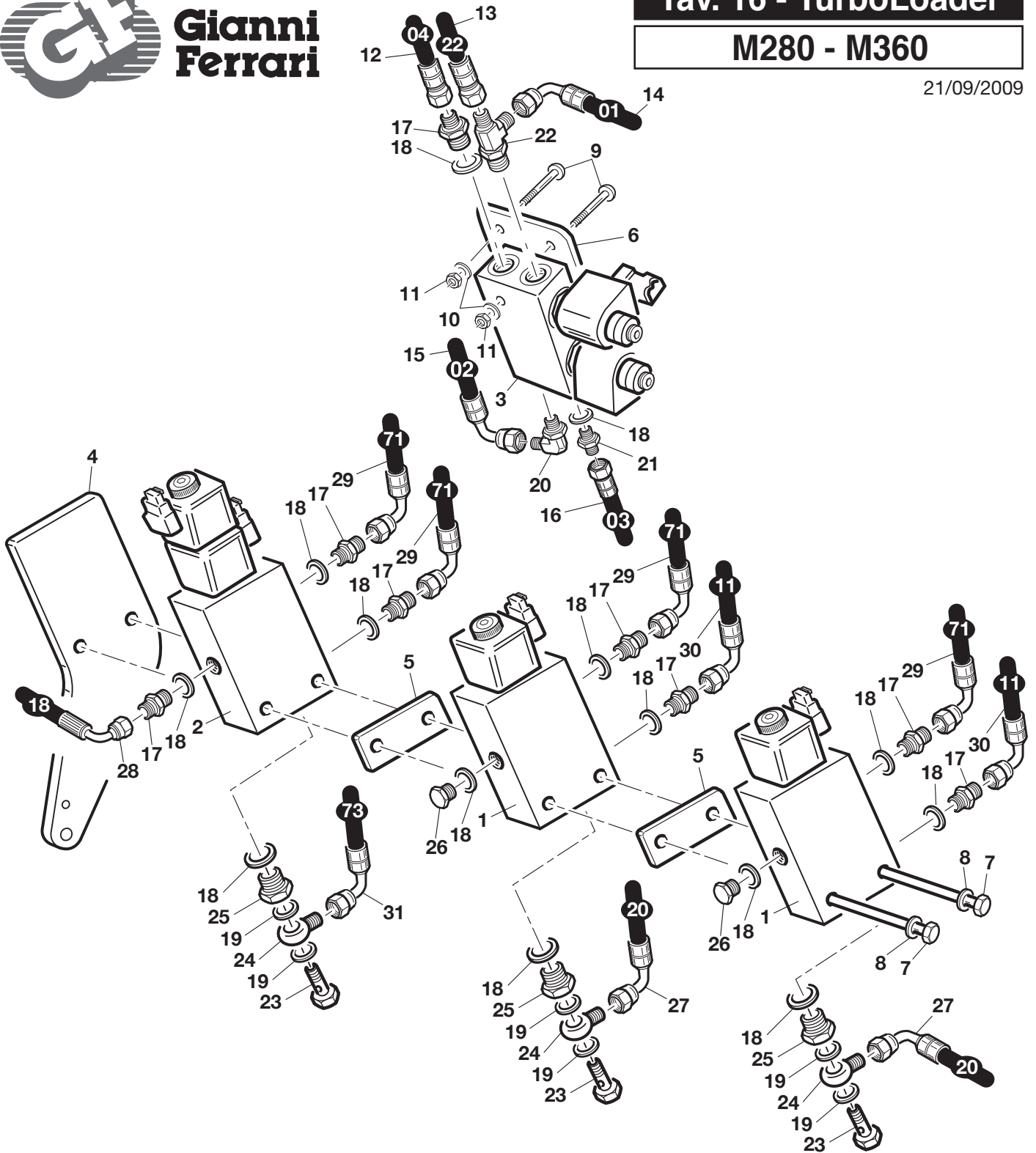

Ref.	Leg.	Code	Q.ty	Ref.	Leg.	Code	Q.ty	Ref.	Leg.	Code	Q.ty
1		00.41.00.3420	2	12		00.41.20.0013	1	23		00.41.00.0121	3
2		00.41.00.3423	1	13		00.41.20.0139	1	24		00.41.00.0243	3
3		00.41.00.3660	1	14		00.41.20.0010	1	25		00.41.00.0915	3
4		01.60.20.0511	1	15		00.41.20.0011	1	26		00.85.02.0002	2
5		01.60.20.0640	2	16		00.41.20.0012	1	27		00.41.20.0029	2
6		01.60.20.0323	1	17		00.41.00.0780	8	28		00.41.20.0027	1
7		00.92.03.0270	2	18		00.41.00.0060	14	29		00.41.20.0103	2
8		00.68.01.0020	2	19		00.41.00.0061	6	30		00.41.20.0020	2
9		00.90.06.3150	2	20		00.41.00.0874	1	31		00.41.20.0105	1
10		00.68.01.0030	2	21		00.41.00.0450	1				
11		00.26.05.0060	2	22		00.41.00.2101	1				

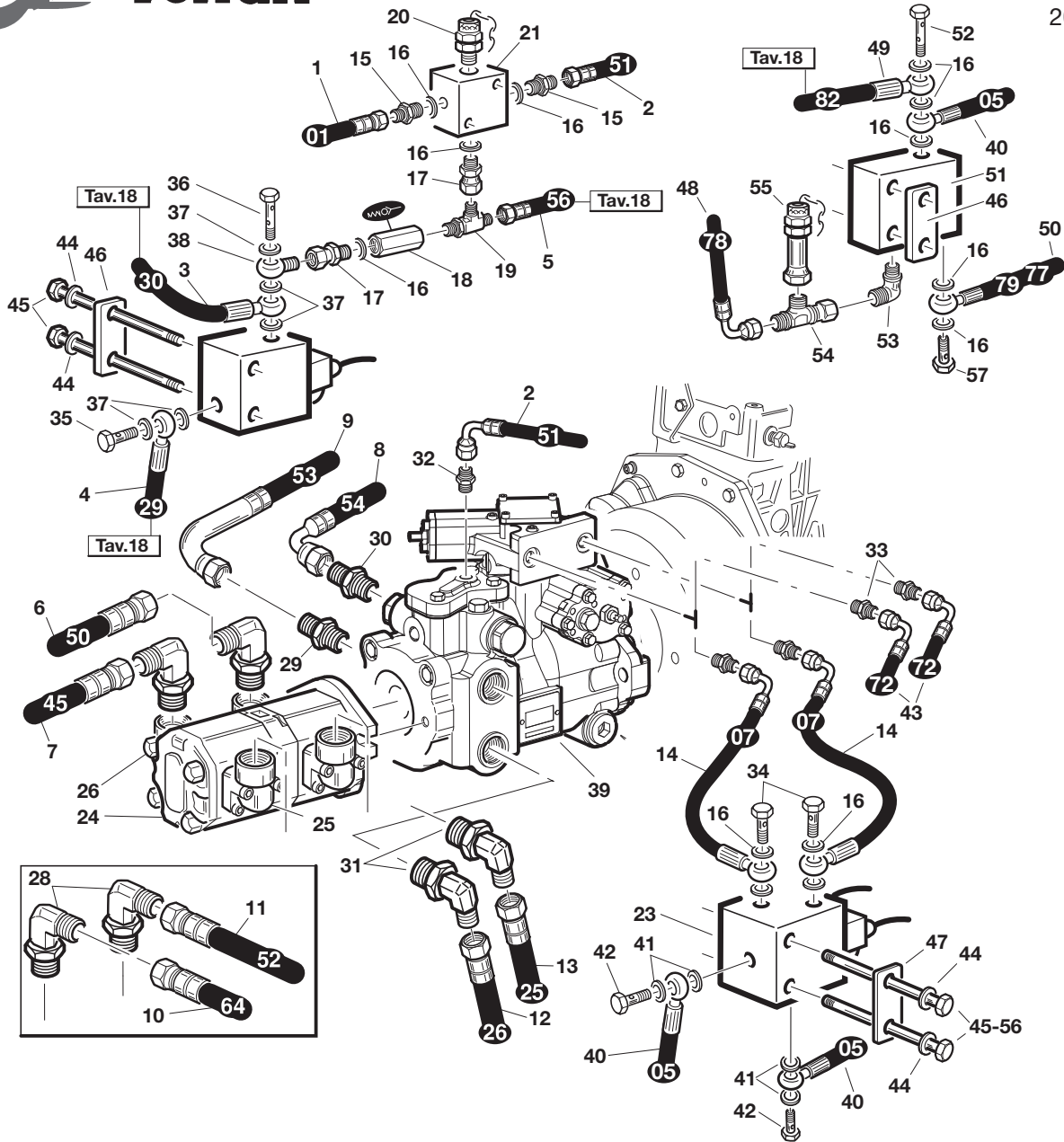

Ref.	Leg.	Code	Q.ty	Ref.	Leg.	Code	Q.ty	Ref.	Leg.	Code	Q.ty
1		00.41.20.0010	1	21		00.41.00.1920	1	40		00.41.20.0014	3
2		00.41.20.0060	2	22		00.41.00.3580	1	41		00.41.00.0060	4
3		00.41.20.0039	1	23		00.41.00.3423	1	42		00.41.00.0240	2
4		00.41.20.0038	1	24		00.41.00.3550	1	43		00.41.20.0104	2
5		00.41.20.0065	1	25		00.41.00.0189	2	44		00.68.01.0020	4
6		00.41.20.0059	1	26		00.41.00.0188	2	45		00.92.03.0280	4
7		00.41.20.0054	1	27		00.41.00.0876	2	46		01.60.20.0640	2
8		00.41.20.0062	1	28		00.41.00.0878	2	47		01.60.20.0842	1
9		00.41.20.0063	1	29		00.41.00.0828	1	48		00.41.20.0123	1
10		00.41.20.0073	1	30		00.41.00.1276	1	49		00.41.20.0135	1
11		00.41.20.0061	1	31		00.41.00.2869	2	50	M280	00.41.20.0122	1
12		00.41.20.0035	1	32		00.41.00.0812	1	50	M360	00.41.20.0124	1
13		00.41.20.0144	1	33		00.41.00.0810	4	51		00.41.00.0531	1
14		00.41.20.0016	2	34		00.41.00.0120	2	52		01.41.00.0127	1
15		00.41.00.0450	2	35		00.41.00.0250	1	53		00.41.00.0874	1
16		00.41.00.0060	13	36		00.41.00.0253	1	54		00.41.00.0350	1
17		00.41.00.2821	2	37		00.41.00.0070	5	55		00.41.00.0468	1
18		00.41.00.0292	1	38		00.41.00.0241	1	56		00.92.03.0300	2
19		00.41.00.2101	1	39	M280	00.41.00.3545	1	57		00.41.00.0128	1
20		00.41.00.3085	1	39	M360	00.41.00.3540	1				

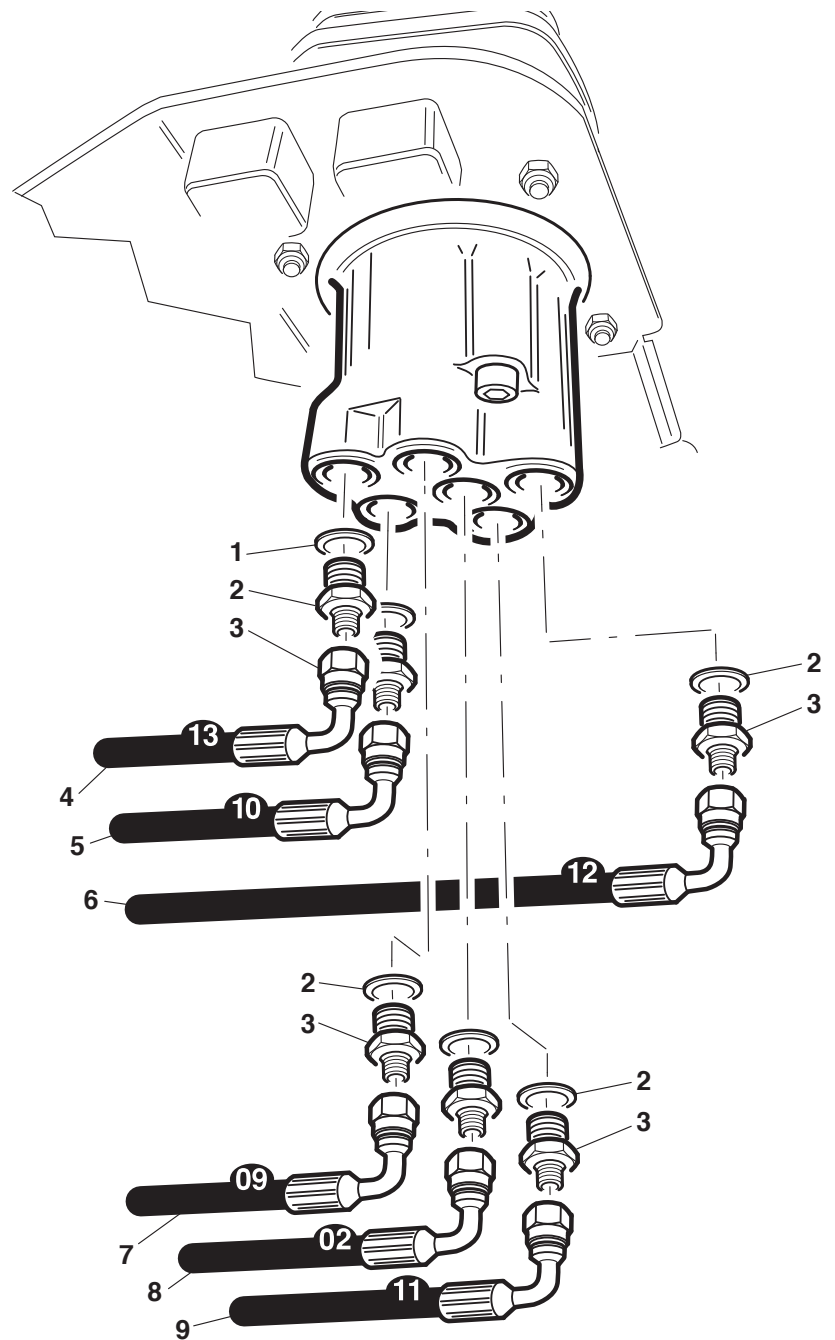
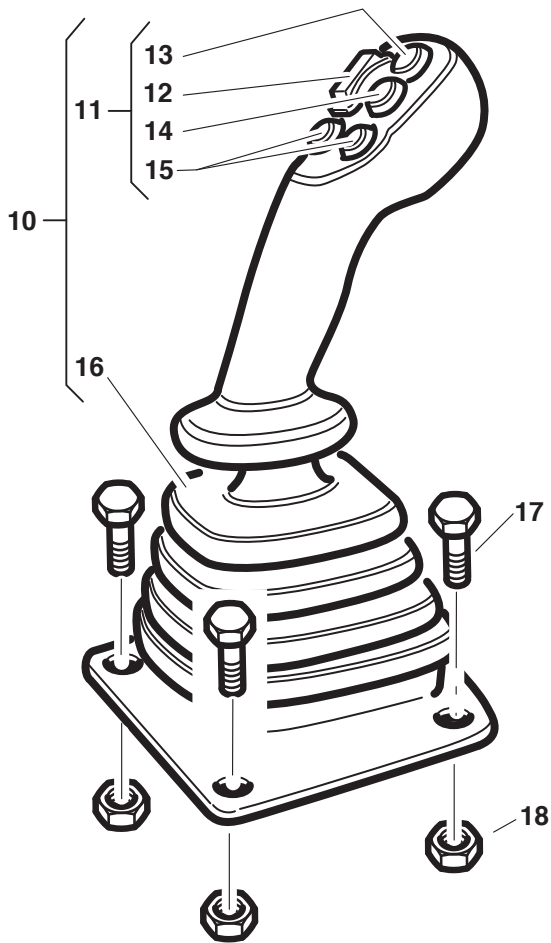

Ref.	Leg.	Code	Q.ty
1		00.41.00.3650	1
2		00.41.00.0060	6
3		00.41.00.0780	6
4		00.41.20.0022	1
5		00.41.20.0019	1
6		00.41.20.0021	1
7		00.41.20.0018	1
8		00.41.20.0011	1
9		00.41.20.0020	1
10		00.41.00.3650	1
10		00.41.00.3651	1

Ref.	Leg.	Code	Q.ty
11		00.40.00.2500	1
11		00.40.00.2501	1
12		00.40.00.2502	1
12		00.40.00.2503	1
13		00.40.00.2504	1
14		00.40.00.2506	1
15		00.40.00.2505	2
16		00.07.01.0124	1
17		00.92.03.1070	4
18		00.26.03.0040	4



Gianni Ferrari

1G53100

Tav. 20 - TurboLoader

M280 - M360

24/04/2011

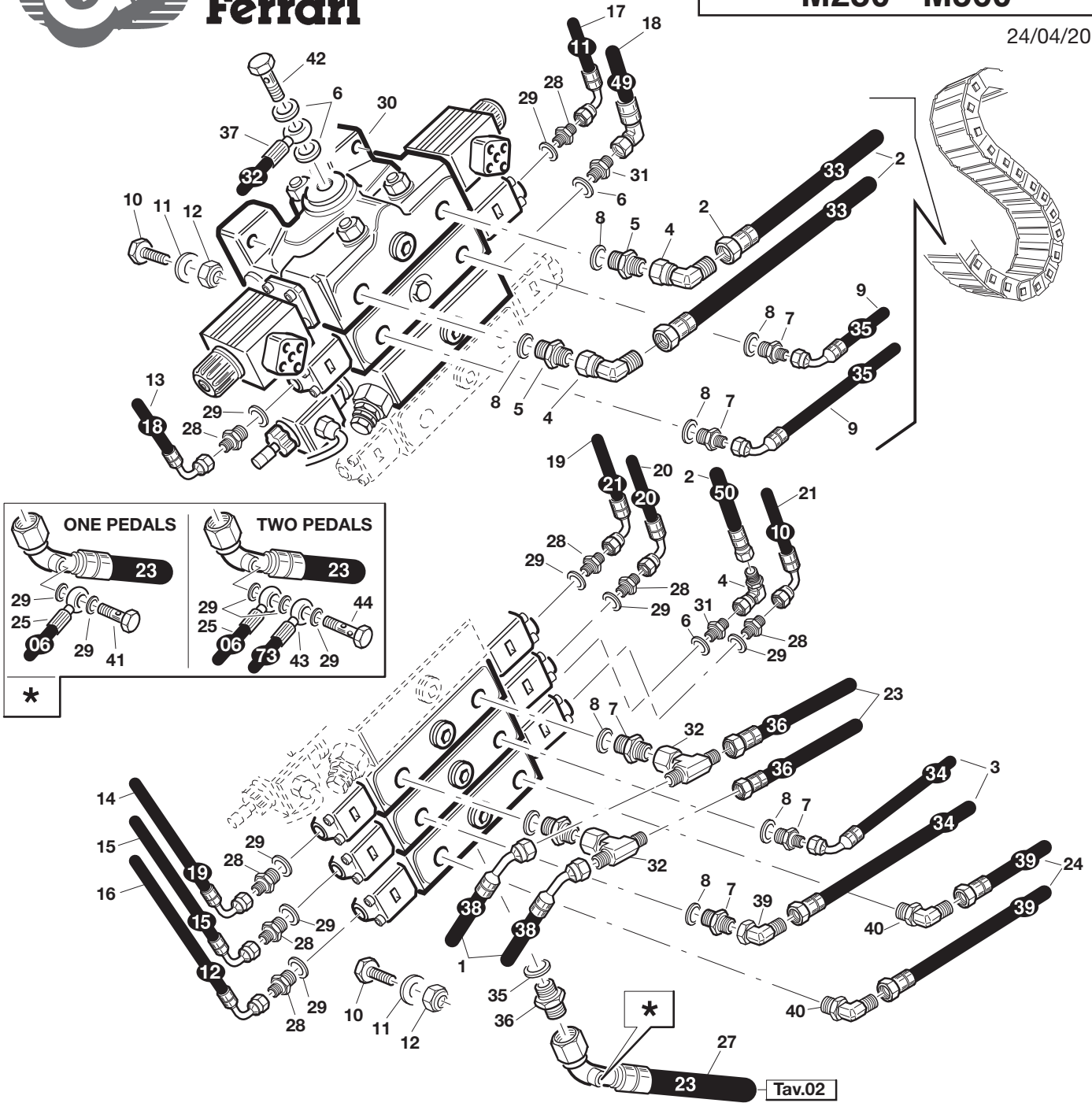

Ref.	Leg.	Code	Q.ty	Ref.	Leg.	Code	Q.ty	Ref.	Leg.	Code	Q.ty
1		00.41.20.0047	2	17		00.41.20.0020	1	32		00.41.00.0731	2
2		00.41.20.0042	2	18		00.41.20.0058	1	33		00.41.00.0881	1
3		00.41.20.0043	1	19		00.41.20.0030	1	34		00.41.00.2821	1
4		00.41.00.0872	2	20		00.41.20.0029	1	35		00.41.00.0073	1
5		00.41.00.0784	2	21		00.41.20.0019	1	36		00.41.00.0794	1
6		00.41.00.0071	4	22		00.41.20.0059	1	37		00.41.20.0041	1
7		00.41.00.0110	5	23		00.41.20.0045	2	38		00.41.00.3085	1
8		00.41.00.0070	8	24		00.41.20.0048	2	39		00.41.00.0871	1
9		00.41.20.0044	2	25		00.41.20.0015	1	40		00.41.00.0875	2
10		00.90.06.3130	4	26		00.41.20.0052	1	41		00.41.00.0120	1
11		00.68.01.0030	4	27		00.41.20.0081	1	42		00.41.00.0125	1
12		00.26.05.0060	4	28		00.41.00.0780	8	43		00.42.20.0105	1
13		00.41.20.0027	1	29		00.41.00.0060	10	44		00.41.00.0124	1
14		00.41.20.0028	1	30		00.41.00.3630	1				
16		00.41.20.0021	1	31		00.41.00.0113	2				

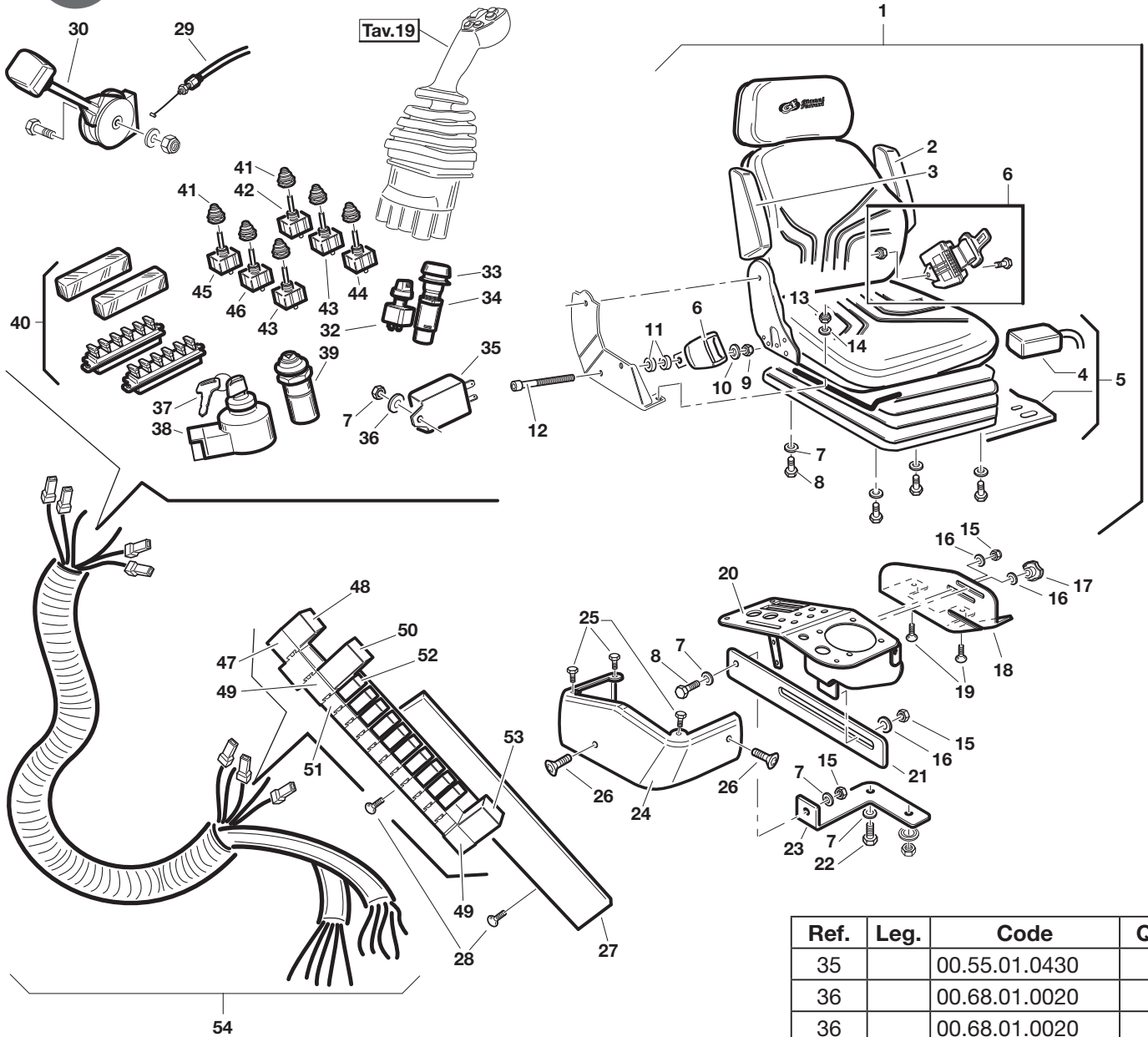

Ref.	Leg.	Code	Q.ty
35		00.55.01.0430	1
36		00.68.01.0020	1
36		00.68.01.0020	1
37		00.40.00.0091	1
38		00.55.01.0091	1
39		00.40.00.0882	1
40		00.40.00.0922	2
41		00.40.00.2514	6
42		00.40.00.2508	1
43		00.40.00.2509	2
44		00.40.00.2510	1
45		00.40.00.2511	1
46		00.40.00.2512	1
47		00.40.00.0169	1
48		00.40.00.0160	1
49		00.40.00.2515	2
50		00.40.00.2516	1
51		00.40.00.0164	11
52		00.40.00.0163	11
53		00.40.00.2517	1
54		00.40.00.2280	1

Ref.	Leg.	Code	Q.ty	Ref.	Leg.	Code	Q.ty
1		00.73.00.0030	1	17		00.45.00.0007	1
1	H	00.73.00.0050	1	18		01.60.20.0524	1
2		00.73.00.0034	1	19		00.95.04.0060	2
3		00.73.00.0033	1	20		01.50.20.0133	1
4		00.40.00.0561	1	21		01.60.20.0525	1
5		00.40.00.0562	1	22		00.92.05.1040	1
6		00.73.00.0035	1	23		01.60.20.0522	1
7		00.68.01.0030	8	24		01.30.20.0013	1
8		00.92.05.1070	5	25		00.91.04.0050	3
9		00.26.04.0070	1	26		00.90.04.3070	2
10		00.68.01.0040	1	27		01.50.20.0020	1
11		01.40.00.2120	2	28		00.95.04.0030	2
12		00.90.08.3270	1	29		00.25.01.0170	1
13		00.26.04.0040	1	30		00.25.02.0030	1
14		00.68..02.0030	1	32		00.40.00.0910	1
15		00.26.04.0060	3	33		00.40.00.2236	1
16		00.68.02.0050	3	34		00.40.00.2235	1

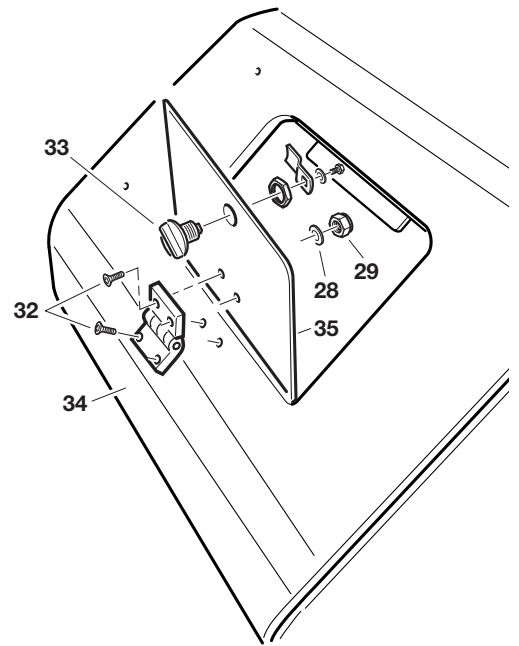
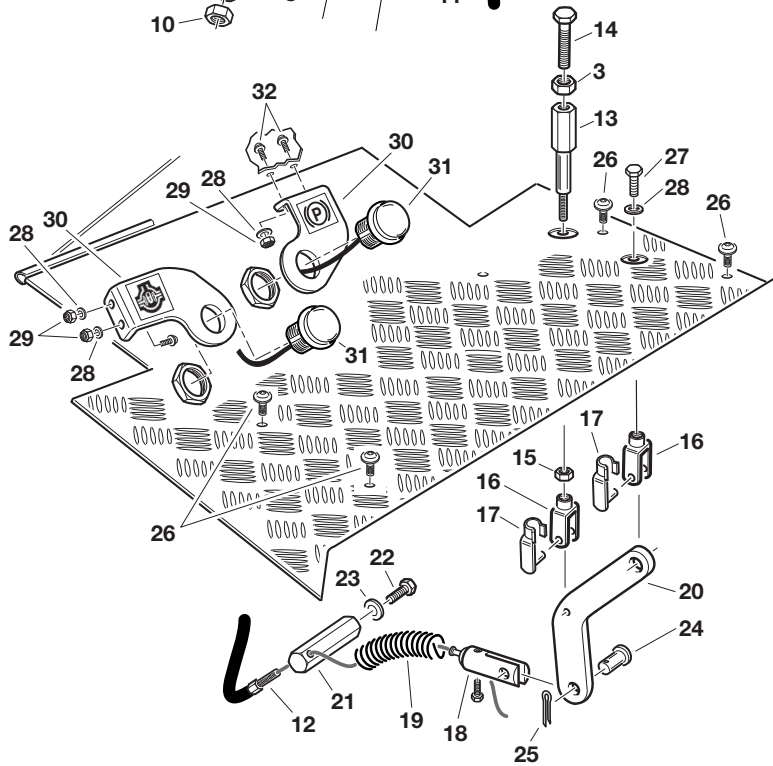
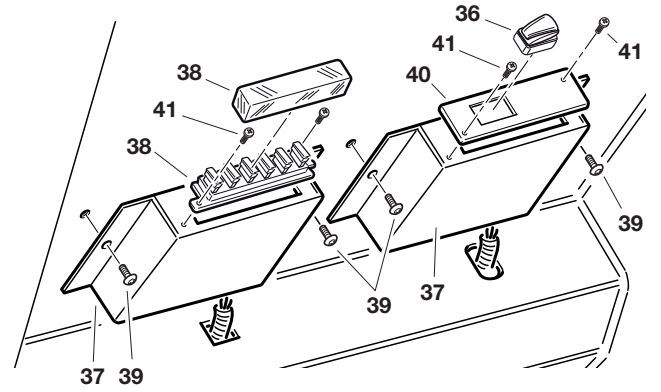
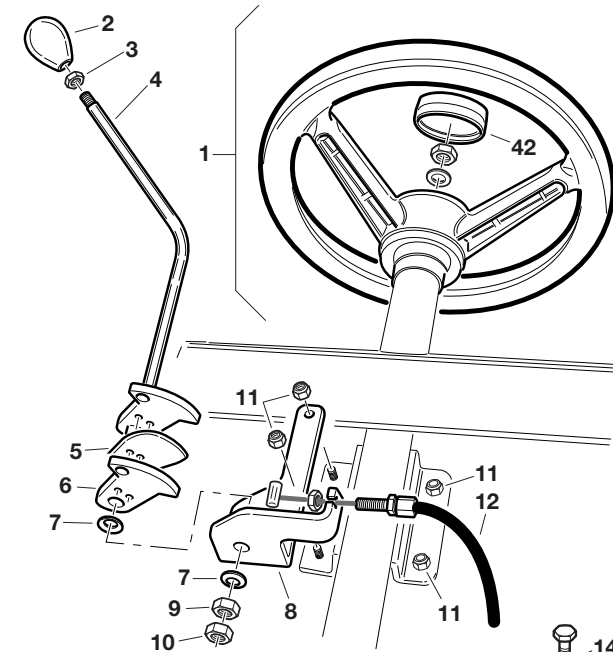

Ref.	Leg.	Code	Q.ty	Ref.	Leg.	Code	Q.ty	Ref.	Leg.	Code	Q.ty
1		00.25.03.0020	1	15		00.26.03.0040	1	29		00.26.04.0040	8
2		00.45.01.0011	1	16		00.33.01.0020	2	30		01.60.20.0673	2
3		00.26.02.0060	2	17		00.33.01.0021	2	31		00.40.00.2229	2
4		01.50.20.0129	1	18		01.40.00.4930	1	32		00.95.04.0060	6
5		01.60.20.0502	1	19		00.47.20.0010	1	33		00.99.00.0300	1
6		01.60.20.0501	1	20		01.60.20.0499	1	34		00.99.00.0240	1
7		00.48.00.0160	4	21		01.40.20.0110	1	35		01.50.20.0047	1
8		01.60.20.0495	1	22		00.92.05.1080	1	36		00.40.00.2230	1
9		00.26.01.0080	1	23		00.62.01.0030	1	37		01.50.20.0390	2
10		00.26.03.0080	1	24		00.33.02.0022	1	38		00.40.00.0922	1
11		00.26.05.0060	4	25		00.18.04.0021	1	39		00.90.04.3030	4
12		00.25.01.0181	1	26		00.90.06.3100	4	40		01.60.20.0719	1
13		01.40.20.0111	1	27		00.92.03.1070	1	41		00.91.04.1050	4
14		00.92.05.1070	1	28		00.68.01.0011	9	42		00.25.03.0021	1

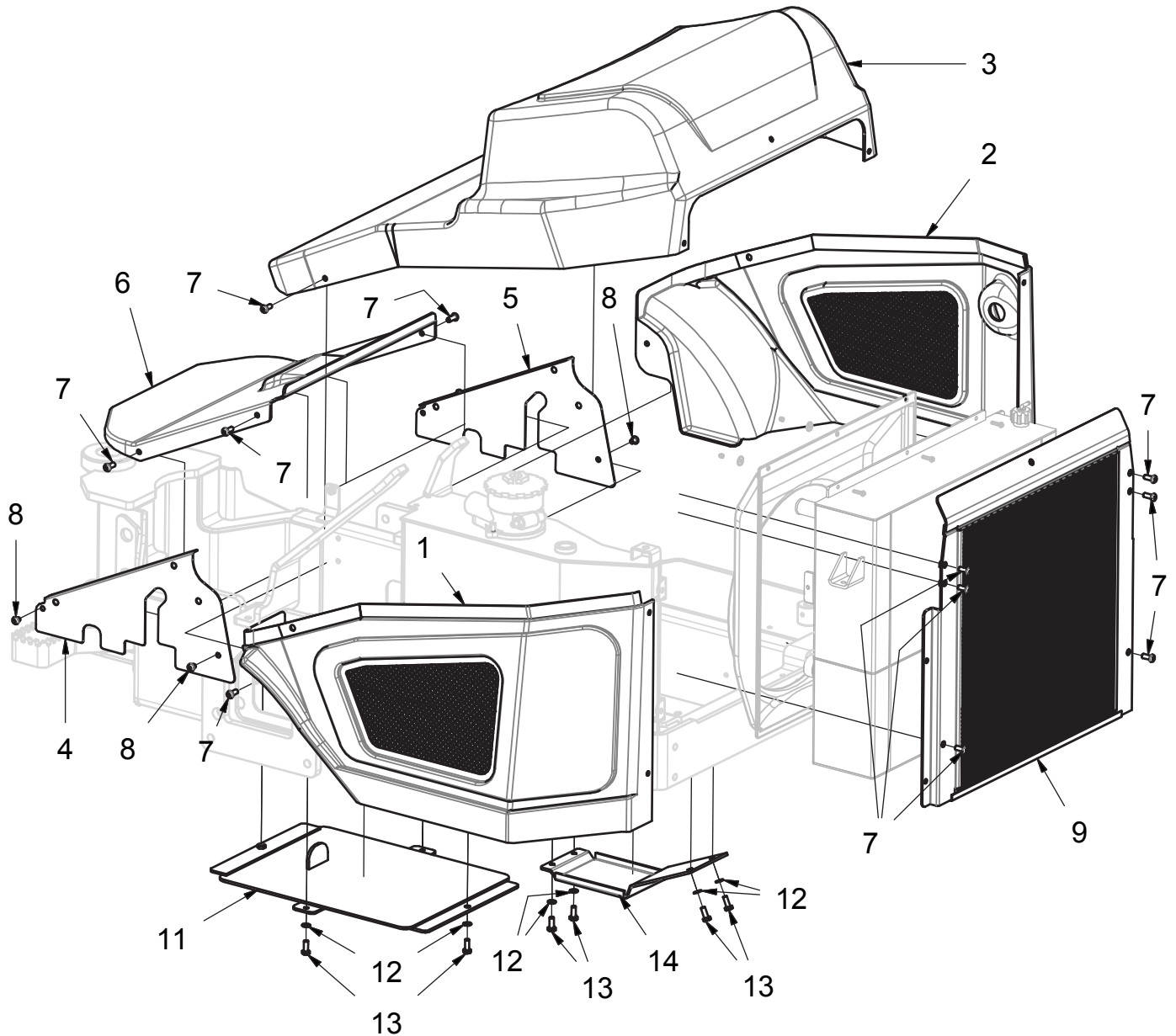

Ref.	Leg.	Code	Q.ty	Ref.	Leg.	Code	Q.ty
1		01.90.20.0060	1	7		00.90.06.3080	14
2		01.90.20.0102	1	8		00.90.04.3090	4
3		01.30.20.0015	1	9		01.50.20.0112	1
4		01.60.20.0153	1	10		01.60.20.0250	1
5		01.60.20.0121	1	11		01.60.20.0247	1
6		01.30.20.0022	1	12		00.68.01.0030	8
				13		00.92.05.1070	8

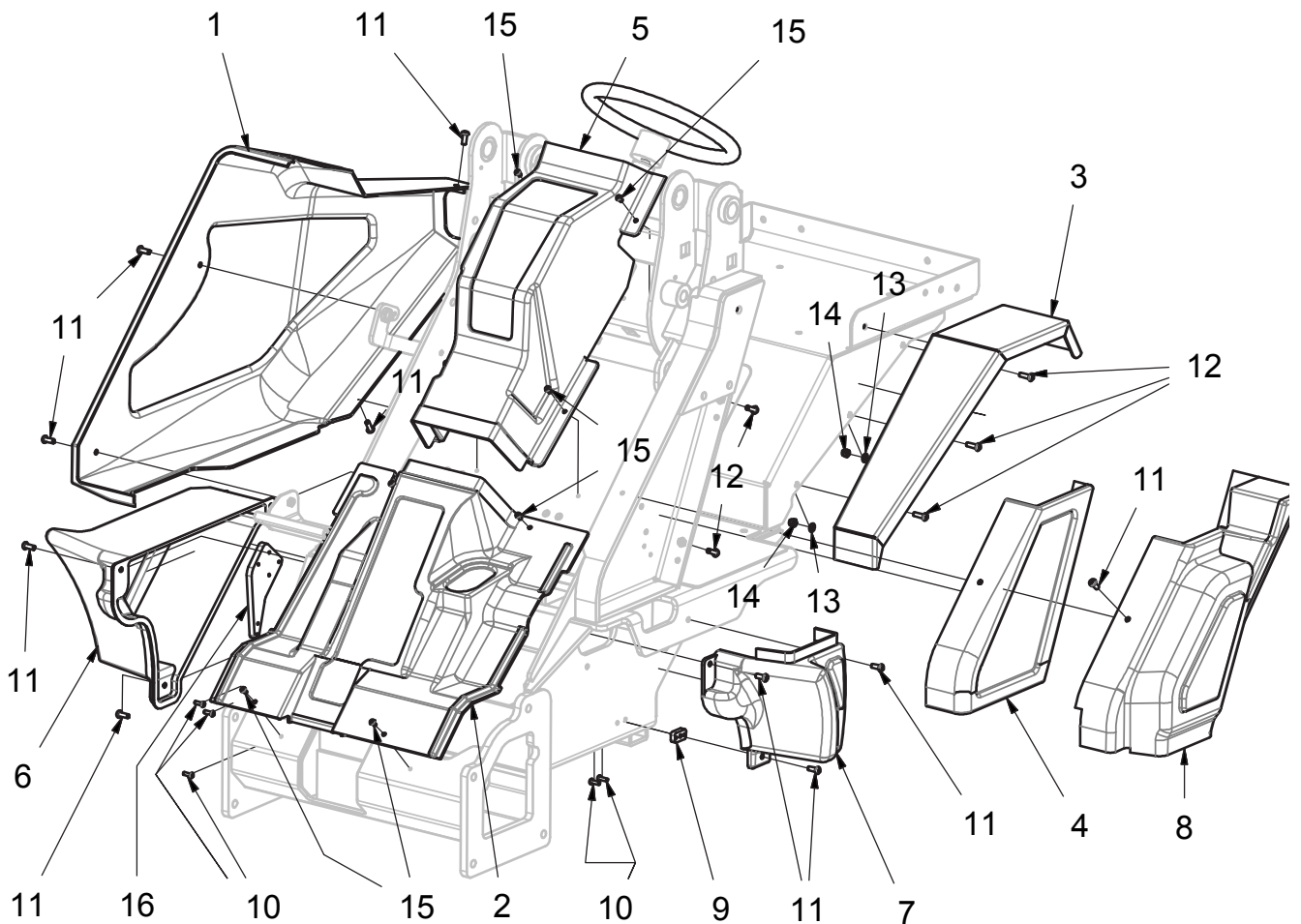

Ref.	Leg.	Code	Q.ty	Ref.	Leg.	Code	Q.ty
1		01.30.20.0014	1	9		01.60.20.0739	1
2		01.30.20.0019	1	10		00.90.04.3070	5
3		01.60.20.0207	1	11		00.90.06.3080	17
4		01.30.20.0023	1	12		00.90.06.3100	6
5		01.30.20.0018	1	13		00.62.01.0030	4
6		01.30.20.0041	1	14		00.26.01.0060	4
7		01.30.20.0047	1	15		00.90.04.3040	8
8		01.30.20.0038	1	16		01.60.20.0511	1

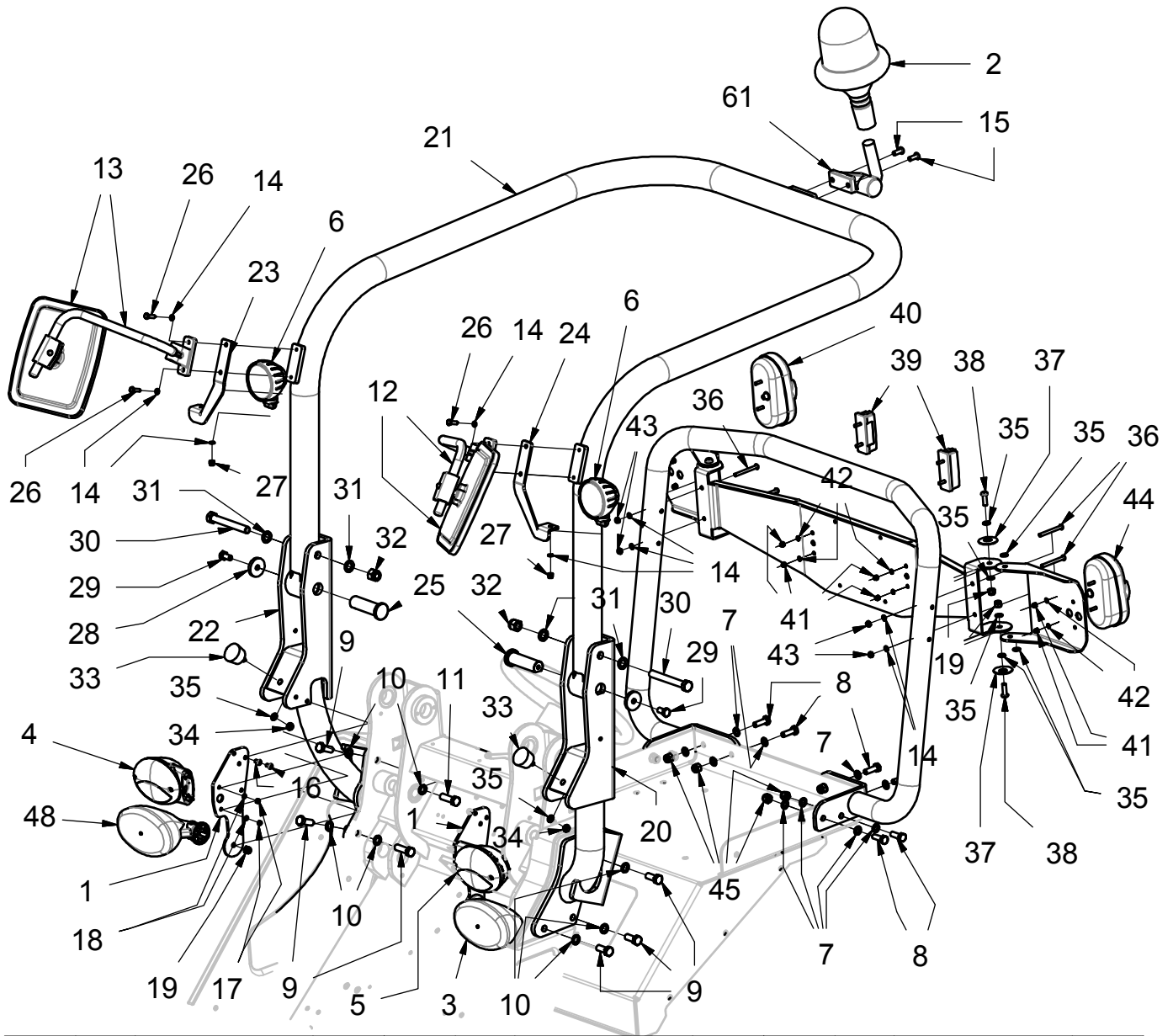

Ref.	Leg.	Code	Q.ty	Ref.	Leg.	Code	Q.ty	Ref.	Leg.	Code	Q.ty
1		01.60.20.0373	2	17		00.26.02.0030	4	33		00.74.00.0030	2
2		00.40.00.0490	1	18		00.68.04.0030	4	34		00.26.02.0060	2
3		00.40.00.1281	1	19		00.26.04.0060	6	35		00.68.01.0030	14
4		00.40.00.1260	1	20		01.50.20.0065	1	36		00.90.04.3130	4
5		00.40.00.1270	1	21		01.50.20.0071	1	37		00.48.00.0183	4
6		00.40.00.1290	2	22		01.50.20.0072	1	38		00.90.06.3100	4
7		00.68.01.0040	16	23		01.60.20.0620	1	39		00.40.00.0550	2
8		00.92.06.1080	8	24		01.60.20.0621	1	40		00.40.00.1220	1
9		00.92.07.1070	5	25		01.40.20.0070	2	41		00.26.04.0030	8
10		00.68.01.0050	9	26		00.92.03.1070	4	42		00.68.01.0010	8
11		00.92.07.1090	2	27		00.26.04.0040	2	43		00.26.05.0040	4
12		00.99.00.0210	1	28		00.68.08.0303	2	44		00.40.00.1210	1
13		00.99.00.0290	1	29		00.92.06.1040	2	45		00.26.04.0080	8
14		00.68.01.0020	10	30		00.92.08.0190	2	46		00.26.05.0040	1
15		00.90.06.3100	2	31		00.68.01.0060	4	47		00.40.00.2010	1
16		00.90.04.3040	4	32		00.26.04.0090	2	48		00.40.00.1280	1

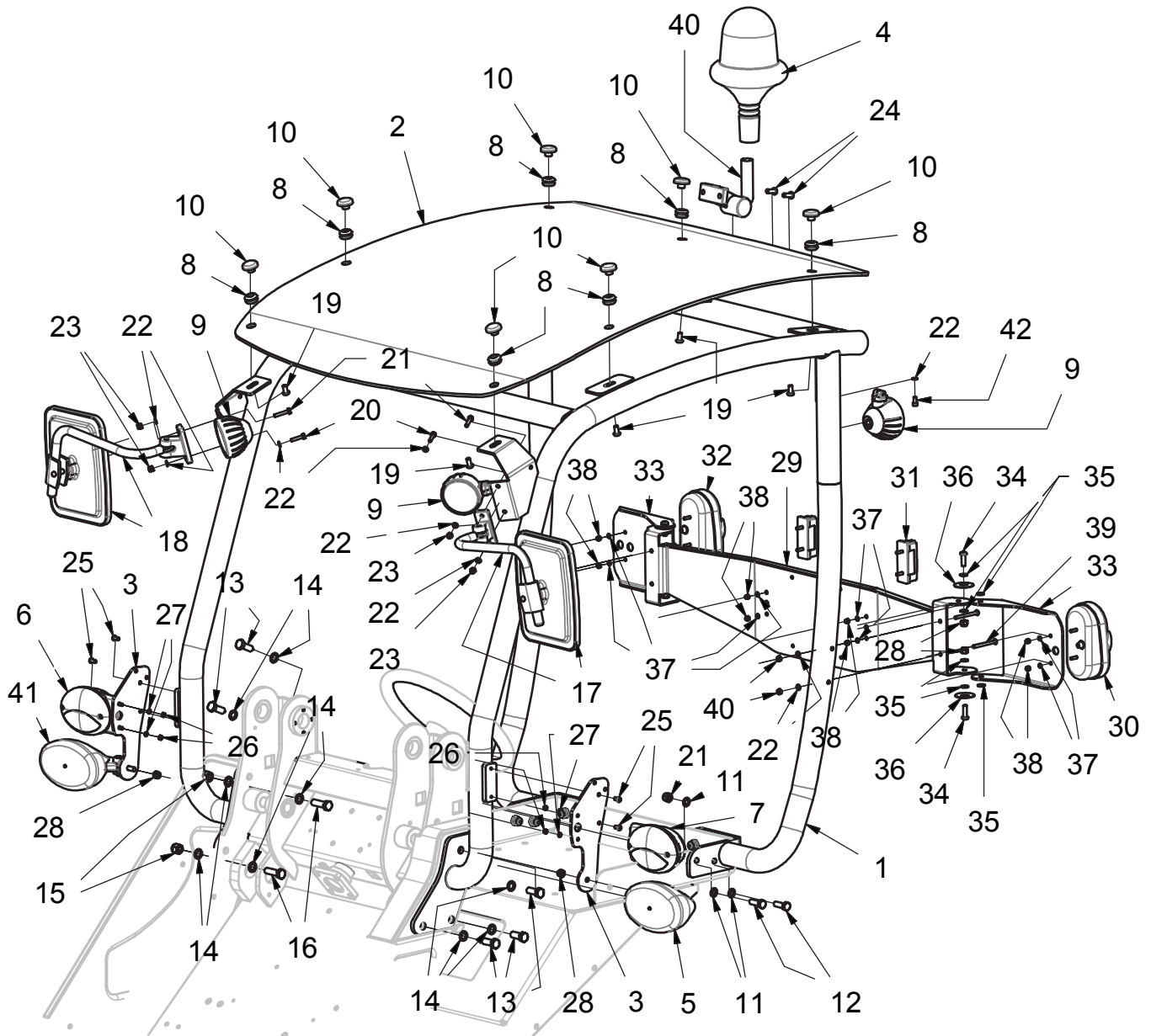

Ref.	Leg.	Code	Q.ty	Ref.	Leg.	Code	Q.ty	Ref.	Leg.	Code	Q.ty
1		01.50.20.0089	1	15		00.26.04.0080	2	29		01.60.20.0356	1
2		00.99.01.0050	1	16		00.92.07.1090	2	30		00.40.00.1210	1
3		01.60.20.0373	2	17		00.99.00.0210	1	31		00.40.00.0550	2
4		00.40.00.0490	1	18		00.99.00.0290	1	32		00.40.00.1220	1
5		00.40.00.1281	1	19		00.90.06.3060	7	33		01.60.20.0124	2
6		00.40.00.1260	1	20		00.92.03.1090	2	34		00.90.06.3100	4
7		00.40.00.1270	1	21		00.92.03.1110	2	35		00.68.01.0030	12
8		00.07.01.0038	7	22		00.68.01.0020	12	36		00.48.00.0183	4
9		00.40.00.1290	4	23		00.26.04.0040	4	37		00.68.01.0010	8
10		00.45.00.0116	7	24		00.90.06.3080	2	38		00.26..04.0030	8
11		00.68.01.0040	16	25		00.90.04.3040	4	39		00.90.04.3130	4
12		00.92.06.1080	8	26		00.26.02.0030	4	40		00.40.00.2010	1
13		00.92.07.1070	5	27		00.68.04.0030	4	41		00.40.00.1280	1
14		00.68.01.0050	9	28		00.26.04.0060	6	42		00.90.04.0050	2

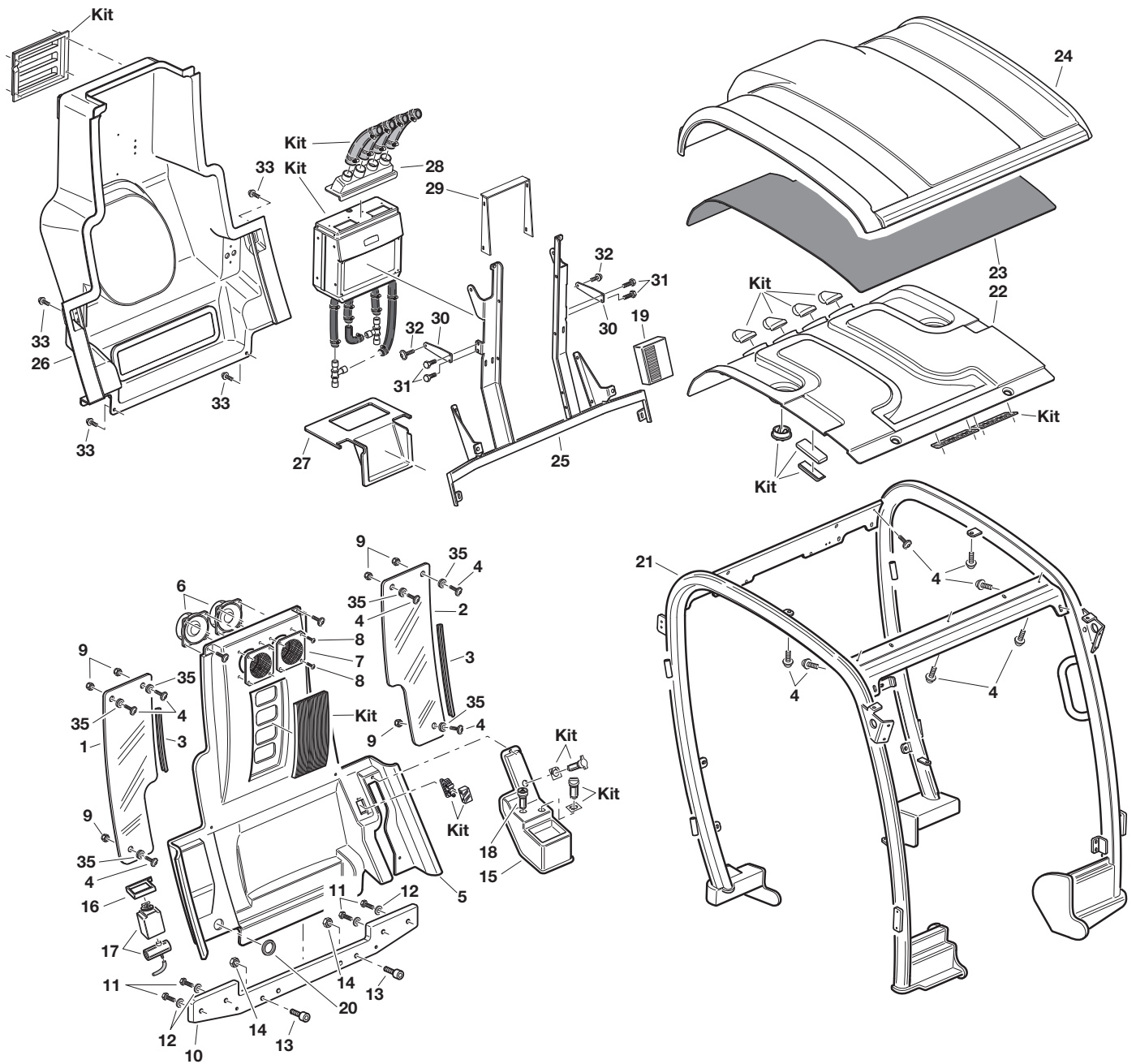

Ref.	Leg.	Code	Q.ty	Ref.	Leg.	Code	Q.ty	Ref.	Leg.	Code	Q.ty
1	DX	00.99.01.0061	1	13		00.90.07.0110	4	25		01.50.20.0041	1
2	SX	00.99.01.0062	1	14		00.26.04.0070	4	26		01.30.20.0045	1
3		00.11.01.0014	ML 3.6	15		01.30.20.0050	1	27		01.30.20.0048	1
4		00.90.06.3100	12	16		01.50.20.0485	1	28		01.30.20.0043	1
5		01.30.20.0036	1	17		00.75.00.0125	1	29		01.60.20.0715	1
6		00.40.00.2520	1	18		00.99.00.0276	1	30		01.60.20.0764	2
7		00.40.00.2519	1	19		00.40.00.2521	1	31		00.92.03.1060	4
8		00.91.04.0080	8	20		00.07.01.0032	1	32		00.90.04.3070	2
9		00.45.00.0116	6	21		01.50.20.0115	1	33		00.90.06.3060	4
10		01.60.20.0438	1	22		01.30.20.0011	1	34	Kit	00.40.10.0010	1
11		00.92.06.1080	4	23		00.07.05.0110	1	35		00.07.01.0038	6
12		00.68.01.0040	12	24		01.30.20.0031	1				

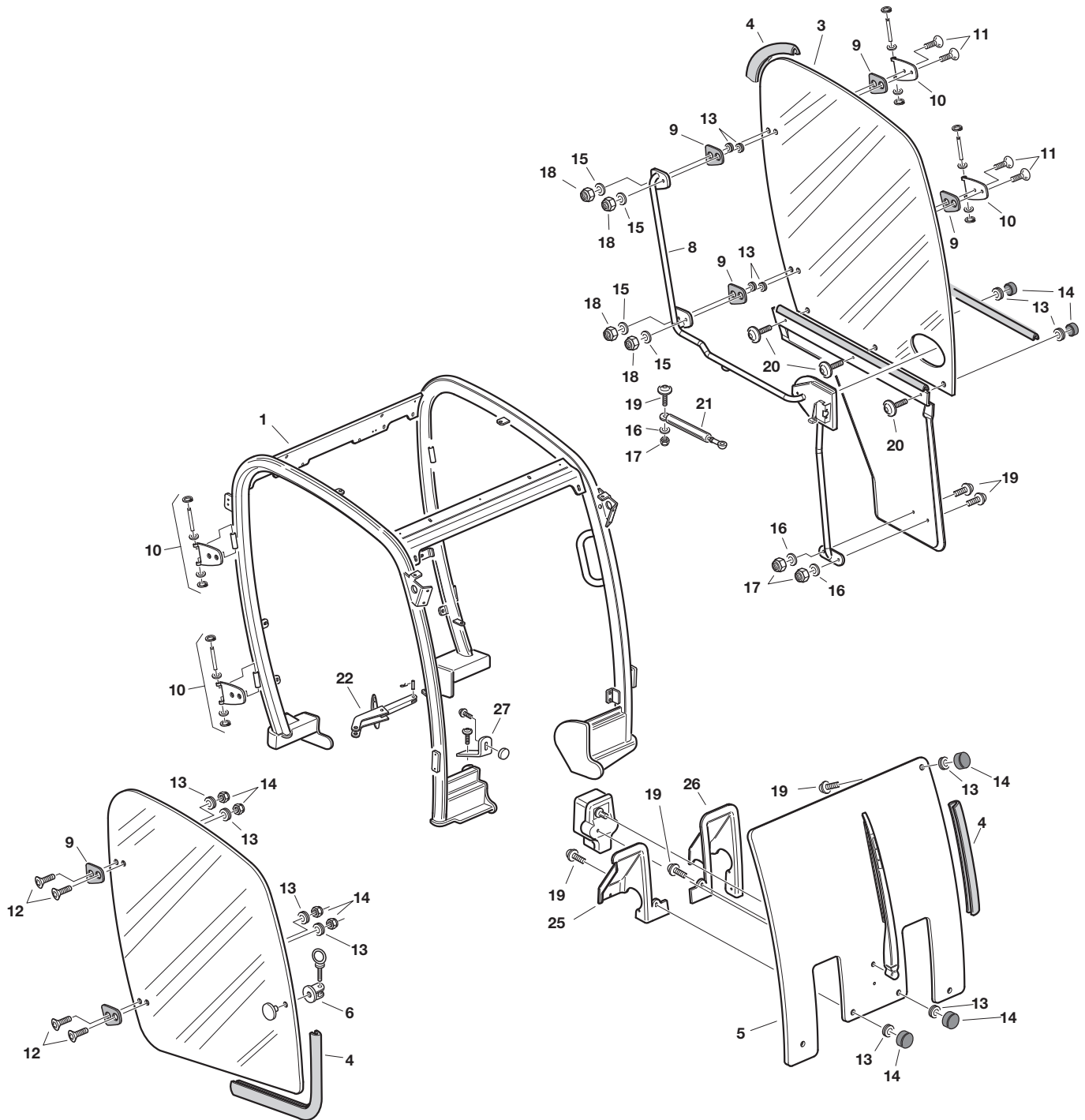

Ref.	Leg.	Code	Q.ty	Ref.	Leg.	Code	Q.ty	Ref.	Leg.	Code	Q.ty
1		01.50.20.0115	1	11		00.95.06.0100	4	20		00.90.06.3060	3
2		00.99.01.0056	1	12		00.95.05.0020	4	21		01.90.20.0116	1
3		00.99.01.0057	1	13		00.07.01.0038	23	22		00.99.00.0273	1
4		00.11.01.0014	ML 17.5	14		00.45.00.0116	19	23		00.99.00.0500	1
5		00.99.01.0051	1	15		00.68.01.0040	4	24		01.30.20.0030	1
6		00.99.00.0273	1	16		00.68.01.0030	3	25		01.60.20.0803	1
8		01.50.20.0121	1	17		00.26.04.0060	3	26		01.30.20.0029	1
9		00.07.01.0280	6	18		00.26.04.0070	4	27		01.60.20.0734	1
10		00.99.00.0241	4	19		00.90.06.3100	9				



Advanced Groundcare Solutions™

